

DIMENSION TABLE

UNIT: mm

NOMINAL SIZE	JIS 10K																						ACTUATOR Model No.		
	d	C	h	N (Number of Bolt Holes)	n (Through hole)	n1 (Screw hole)		M	B	D	D ₁	D ₂	L	L ₁	L ₂	H ₁	H ₂	H ₃	A	A ₁	A ₂	A ₃		P	
700mm	28"	670	840	33	24	20	4	8	M30	28	938	750	364	165	169	2	574	555	468	560.5	306	140	247	3/8	EPTC106-295-DA
800	32	778	950	33	28	24	4	8	M30	30	1060	869	409	190	198	4	639	620	512.5	664.5	399	170	289.5	1/2	EPTC108-340-DA
900	36	888	1050	33	28	24	4	8	M30	30	1178	979	409	203	211	4	724	705	512.5	664.5	399	170	289.5	1/2	EPTC108-340-DA

NOTE.

- Dimensions "L" is equivalent to ISO5752 flangeless (wafer) short.
- Operating pressure: 0.5-0.55MPa G
Valve open; Port (a) Exhaust Port (b) Supply
Valve close; Port (a) Supply Port (b) Exhaust
- The shape and appearance of assembly differ a little with nominal size compared to this drawing.

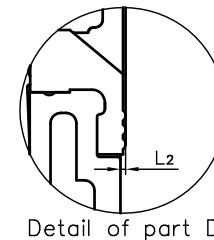
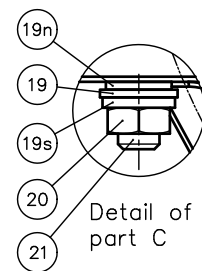
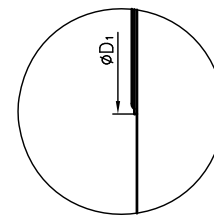
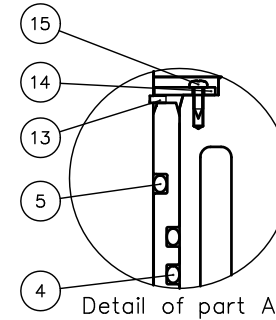
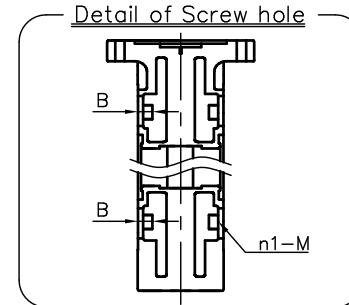
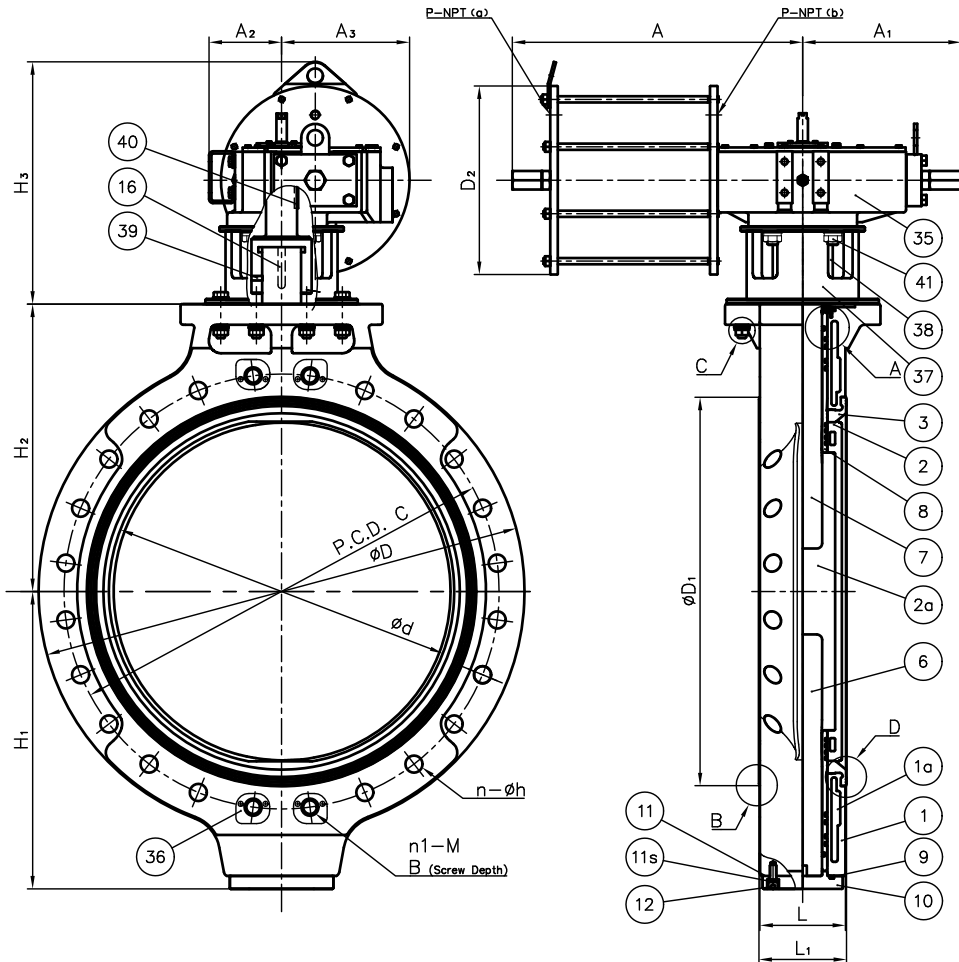

No.	DESCRIPTION	QTY.	MATERIAL	REMARKS
40	KEY	2	CARBON STEEL	
39	SCREW (C)	1	STAINLESS STEEL (SUS304)	
41	BOLT (E)	4sets 8sets	STAINLESS STEEL (SUS304)	
38	JOINT (A)	1	STAINLESS STEEL (SUS304)	
37	STAND	1	STAINLESS STEEL (SUS304)	
36	COVER PLATE	8	ABS	
21	BOLT (B)	8	STAINLESS STEEL (SUS304)	Attachment : Collar
20	NUT	8	STAINLESS STEEL (SUS304)	
19s	SPRING WASHER	8	STAINLESS STEEL (SUS304)	
19	WASHER (B)	8	STAINLESS STEEL (SUS304)	
19n	NORD-LOCK WASHER	8	STAINLESS STEEL (SUS316L)	
35	ACTUATOR	1	Steel/Ductile Iron	Urethane coat (FLOWBUS)
16	KEY	1	CARBON STEEL (S45C)	
15	SCREW	4	STAINLESS STEEL (SUS304)	
14	STEM HOLDER (A)	1	ABS	
13	RETAINING RING C-TYPE	1	STAINLESS STEEL (SUS304)	
12	BOLT (A)	4 8	STAINLESS STEEL (SUS304)	Used for Size 700mm Used for Size 800,900mm
11s	SPRING WASHER (No.11)	4 8	STAINLESS STEEL (SUS304)	Used for Size 700mm Used for Size 800,900mm
11	WASHER (A)	4 8	STAINLESS STEEL (SUS304)	Used for Size 700mm Used for Size 800,900mm
10	STEM HOLDER (B)	1	ABS	
7	STEM (A)	1	STAINLESS STEEL (SUS316)	
6	STEM (B)	1	STAINLESS STEEL (SUS316)	
18	GASKET	1		
9	O-RING (C)	1		
5	O-RING (B)	2	□ EPDM □ FKM	
4	O-RING (A)	16 14		Used for Size 700mm Used for Size 800,900mm
3	SEAT	1		
2a	INSERTED METAL OF DISC	1	AC4C	
8	BUSH	2	□ PP □ PVDF	
2	DISC	1	□ PVDF	
1a	INSERTED METAL OF BODY	2	STEEL CASTING STAINLESS (SCS13)	
1	BODY	1	PDCPD	
No.	DESCRIPTION	QTY.	MATERIAL	REMARKS
ITEM	BUTTERFLY VALVE (TYPE 58) PNEUMATIC MODEL FL TYPE ASS'Y DOUBLE ACTING JIS 10K 700mm (28") ~900mm (36")			
DRAWN	H.Kawano	DATE	SCALE	
CHECKED	Y.Yoneda	MAR.3.2023		
APPROVED	K.Koushou	DRAWING No.		
		58-AA001JE		△
SPECIAL ORDER No.	ASAHI YUKIZAI CORPORATION			