

DIMENSIONS TABLE

UNIT : mm

NOMINAL SIAE	d	JIS 5K				JIS 10K				L	t		D <sub>1</sub>	D <sub>2</sub>	l	H	H <sub>1</sub>	
		D	C	n	h	D	C	n	h		PVC	PP PVDF						
125mm 5"	125	235	200	8	19	250	210	8	23	410	22	24	320	300	60	420	308	
150	6	148	265	230	8	19	280	240	8	23	480	24	27	385	410	70	476	334

NOTE.

- The shape and appearance of assembly differ a little with nominal size compared to this drawing.
- Diaphragms except EPDM and PTFE are available in FKM, VIFLON-C (FKM-C), VIFLON-F (FKM-F), CSM and NBR when required.

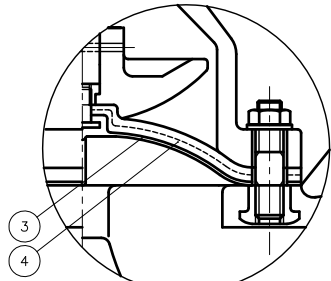

In case material of diaphragm is PTFE.

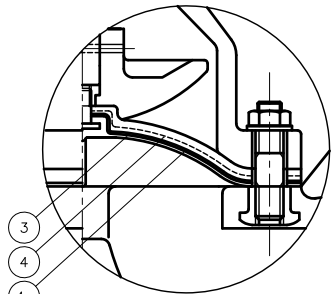

In case material of diaphragm is PTFE with cushion cover.

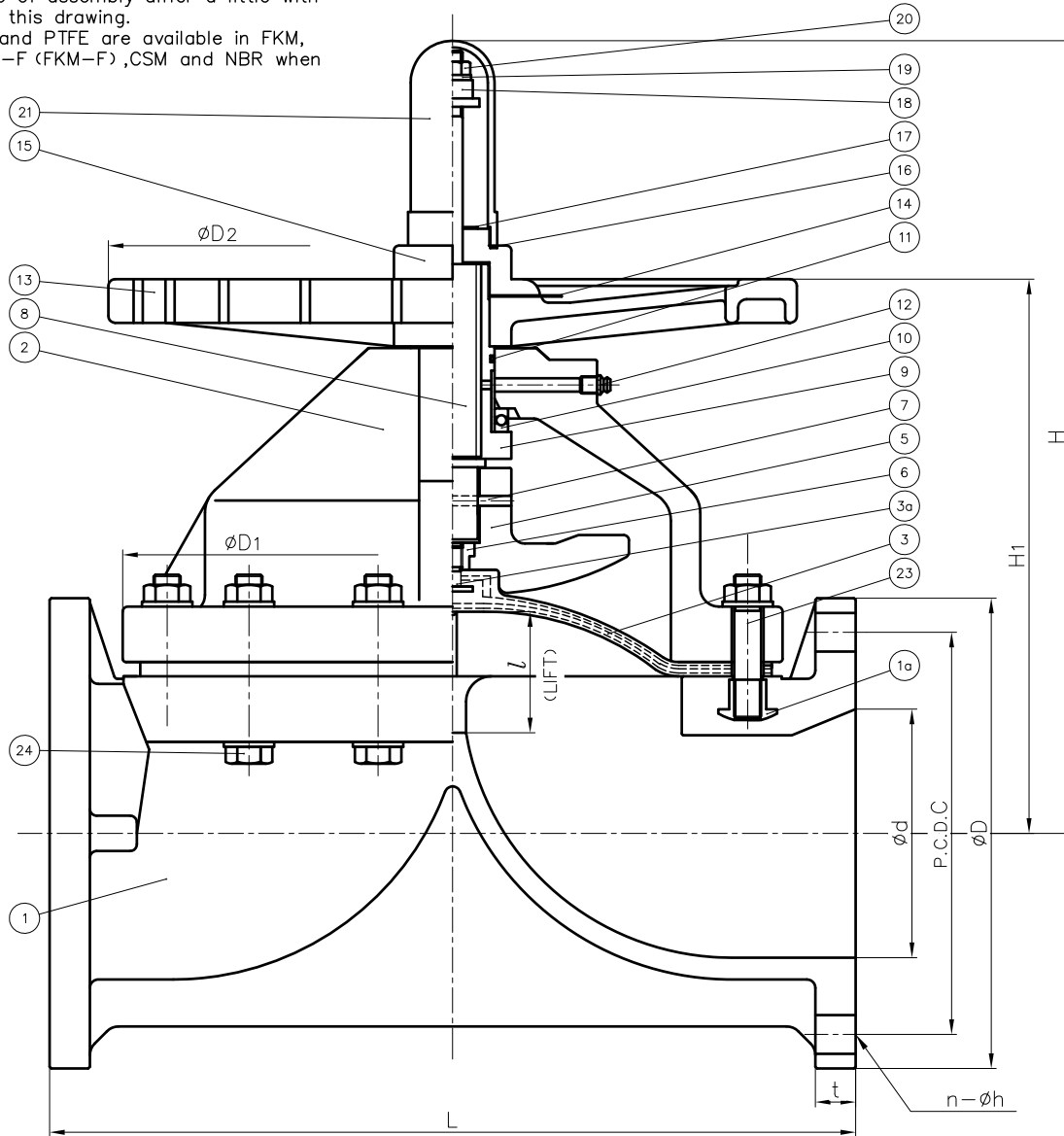

1a	INSERTED NUT	4	COPPER ALLOY (C3604)	used for PVC & PP body
			STAINLESS STEEL (SUS304)	used for PVDF body
24	BOLT · NUT (A)	—	STAINLESS STEEL (SUS304)	
23	STUD BOLT · NUT	4 sets	STAINLESS STEEL (SUS304)	
21	GAUGE COVER	1	PC	
20	NUT	1	STAINLESS STEEL (SUS304)	
19	SPRING WASHER	1	STAINLESS STEEL (SUS304)	
18	STOPPER	1	chromized STEEL (SS400)	
17	SHEET RING	1	STAINLESS STEEL (SUS304)	
16	SHEET GASKET (A)	1	EPDM	
15	CAP	1	PP	
14	NAME PLATE	1	PVC	
13	HAND WHEEL	1	PP	
12	GREASE NIPPLE	1	COPPER ALLOY (C3604)	
11	O-RING (A)	1	NBR	
10	THRUST BEARING (A)	1	HIGH CARBON CHROMIUM BEARING (SUJ2)	
9	SLEEVE (A)	1	COPPER ALLOY (C3604)	
8	STEM	1	COPPER ALLOY (C3604)	
7	COMPRESSOR PIN	1	STAINLESS STEEL (SUS304)	
6	COMPRESSOR NUT	1	COPPER ALLOY (C3604)	
5	COMPRESSOR	1	PVDF	
4a	CUSHION COVER	1	nothing (standard) □PVDF	used for PTFE diaphragm
4	CUSHION	1	□EPDM □others ( )	used for PTFE diaphragm
3a	INSERTED METAL OF DIAPHRAGM (A)	1	STAINLESS STEEL (SUS304)	
3	DIAPHRAGM	1	□EPDM □PTFE □others ( )	
2	BONNET	1	BODY/BONNET □ PVC / PVC □ PP / PP	
1	BODY	1	□ PVDF / PPG □ PVDF / PVDF	

No.	DESCRIPTION	QTY.	MATERIAL	REMARKS
ITEM	DIAPHRAGM VALVE (TYPE 15) ASS'Y □JIS 5K, □JIS 10K: FLANGED END 125mm (5"), 150mm (6")			
DRAWN	M.Iwakiri	DATE	SCALE	
CHECKED	H.Kawano	FEB.12.2019		
APPROVED	K.Koushou	DRAWING No.		
		D5-M1001JE		
SPECIAL ORDER No.	ASAHI YUKIZAI CORPORATION			