

Diaphragm Valve Type 14

15~100mm

True Union Diaphragm Valve Type 14

15~50mm

User's Manual



Thank you for choosing our product.

This instruction manual contains important information for safe use of our product, so please be sure to read it before handling the product.

After reading this manual, please be sure to keep it in a place where the user can see it at any time.

ASAHI YUKIZAI CORPORATION

-SAFETY PRECAUTIONS-



This instruction manual is written on the assumption that the person who handles our products has a basic knowledge of our products, electrical equipment, machinery, control, etc., and it contains technical terms depending on the handling contents.

Please read this manual carefully and fully understand the contents and observe the safety precautions for proper use.

In this manual, the warning, caution, prohibition, and enforcement are categorized together with the symbol to inform the situation and scale of human injury or property damage.

Failure to observe this precaution may result in unexpected failure or damage. Be sure to observe this precaution.

<WARNING/CAUTION indications>

 Warning	Indicates a potentially hazardous situation which, if not avoided, could result in death or serious injury.
 Caution	Indicates a potentially hazardous situation which, if not avoided, may result in minor or moderate injury or property damage.

<Prohibited/Forced display>



 Prohibition	In the handling of the product, it is prohibited to do it in "Do not do it".
 Forcing	In the handling of the product, it is forced by "contents to be carried out without fail".

Table of contents

- 1. Our product warranty coverage.....4**
 - Applicable to 4
 - Warranty Period..... 4
 - Guaranteed range..... 4
 - Disclaimer..... 4
- 2. Safety Instructions.....5**
 - Unpacking, Transportation and Storage..... 5
 - Product Handling..... 6
- 3. Name of parts8**
- 4. Product Specifications10**
 - Product Model Code List 10
 - Relationship between maximum allowable pressure and temperature 11
 - Limit switch specifications 12
- 5. Piping method.....13**
 - Flange type..... 13
 - Threaded type..... 15
 - Socket type (adhesive)..... 17
 - Socket type, Spigot type (fusing) 19
 - Limit switch wiring method 20
- 6. Mounting method of the Ensat and the frame (panel)22**
- 7. Operating procedure.....24**
 - Valve opening and closing operations 24
 - Operating procedure of locking device 25
- 8. Adjustment procedure for stopper.....26**
 - Adjusting Stopper <For 15~50mm> 27
 - Adjusting Stopper <For 65~100mm>..... 28
- 9. Diaphragm replacement procedure29**
- 10. Inspection items.....32**
 - Daily inspection 33
 - Periodic inspection..... 34
- 11. Cause of malfunction and remedy35**
- 12. Handling of residual and waste materials.....36**
- Contact37**

1. Our product warranty coverage

Unless otherwise stated in the Contract or Specifications, etc., the warranty for the piping material products (hereinafter referred to as "applicable products") such as valves manufactured or sold by us is as follows.

Applicable to

This warranty applies only when the product is used in Japan. If you intend to use the product overseas, please contact us.

Warranty Period

The warranty period is one year after delivery.

Guaranteed range

In the event of failure or malfunction due to our responsibility during the above warranty period, we will replace or repair the product with a substitute free of charge.

Provided, however, that even within the warranty period, the warranty shall not apply to any of the following cases (charged service).



- ▶ When the storage, operating conditions, precautions, etc. described in the specifications, instruction manual, etc. are not adhered to in the construction, installation, handling, maintenance, etc.
- ▶ Defects, such as the design of the customer's equipment or software, caused by other than the target product.
- ▶ The fault is due to modification or secondary processing of the product by something other than us.
- ▶ In the case of a failure which can be deemed to have been avoided if the periodic inspection described in the instruction manual, etc. or the maintenance or replacement of consumable parts has been performed normally.
- ▶ The component is used for purposes other than the product's intended use.
- ▶ Failure or malfunction due to causes that could not be foreseen by our level of science and technology at the time of shipment.
- ▶ The fault is due to an external factor that is not our responsibility, such as natural disaster or disaster.



Disclaimer

- ▶ The warranty will not cover secondary damage (damage to equipment, loss of opportunity, loss of profit, etc.) or any other damage caused by the failure of our product.
- ▶ Although we strive to improve the quality and reliability of our products, we do not guarantee their integrity. Especially when using this product for equipment that may infringe human life, body or property, take appropriate safety design measures, etc., with full consideration of problems that may normally occur. We assume no responsibility for such use if we have not obtained our consent in advance in writing of specifications, etc.
- ▶ Please observe the product specifications and precautions when using our products. We shall not assume any responsibility for any damage to the customer caused by the customer's negligence. However, this does not apply to damage caused by a defect in our product.



2. Safety Instructions



Unpacking, Transportation and Storage

 Warning	
 Prohibition	<p>Serious injury can result.</p> <ul style="list-style-type: none"> ▶ When hanging or slinging a valve, pay sufficient attention to safety, and do not enter under the load.

 Caution	
 Prohibition	<p>The valve can be damaged, or leak.</p> <ul style="list-style-type: none"> ▶ Do not subject the product to impact by throwing, dropping or hitting. ▶ Do not scratch or pierce the product with a sharp object such as a knife or hand hook. ▶ Do not pile up cardboard boxes forcefully to prevent the load from collapsing. ▶ Avoid contact with coal tar, creosote (a wood preservative), white pesticides, insecticides, paints, etc. ▶ Do not hang the handle when transporting the valve.
 Forcing	<p>The valve can be damaged, or leak.</p> <ul style="list-style-type: none"> ▶ Keep in cardboard until just before piping, and store indoors (at room temperature) away from direct sunlight. Also, avoid storing the product in places of high temperature. (The strength of cardboard packaging decreases when it gets wet. Be very careful when storing and handling it.) ▶ After unpacking, make sure that the product is correct and that it meets the specifications.

Product Handling

 Warning	
 Forcing	<p>The valve can be damaged or seriously injured.</p> <ul style="list-style-type: none"> ▶ If positive pressure gas is used for our resin piping material, a dangerous condition may occur due to the repulsive force peculiar to compressible fluids even if the pressure is the same as the water pressure. Therefore, be sure to take safety measures for the surrounding area, such as covering the piping with protective materials. If you have any questions, please contact us separately. ▶ When conducting a pipe leak test after completion of piping construction, be sure to check with water pressure. Contact us in advance if you are unavoidable to test with a gas.

 Caution	
 Prohibition	<p>The valve can be damaged, or leak.</p> <ul style="list-style-type: none"> ▶ Do not step on the valve or place heavy objects on it. ▶ Keep away from fire and hot objects. ▶ Do not subject the valve to large vibrations. ▶ Do not use instruments or tools to assist manual operation.
 Forcing	<p>There is a danger of injury.</p> <ul style="list-style-type: none"> ▶ Secure sufficient space for maintenance and inspection when piping. <p>The valve can be damaged, or leak.</p> <ul style="list-style-type: none"> ▶ Pay attention to the atmosphere where the valve is installed. Avoid locations where the product is exposed to sea breezes, corrosive gases, chemical liquids, sea water, steam, etc. ▶ Use a valve of suitable material for the operating conditions. (Depending on the type of chemical liquid, the parts may be damaged. Contact us in advance for details.) ▶ Use fluids containing crystalline material under conditions that do not recrystallize. ▶ Avoid any place where the valve is constantly exposed to splashes of water and dust, or direct sunlight, or protect the valve with a cover or the like to cover the entire area. ▶ Perform maintenance periodically by referring to "10. Inspection items". Pay particular attention to temperature changes and aging during long-term storage or shutdown or use. ▶ If internal leakage occurs when the valve is fully closed, adjust the stopper.

 **Caution****Forcing****The valve can be damaged, or leak.**

- ▶ The tightening bolts and nuts at the diaphragm (between the bonnet and body) may become loose due to changes in temperature during storage or use, and creep. After inspection, tighten the bolts and nuts diagonally to the values listed in the "**bonnet tightening torque table**" in **9. How to replace the diaphragm.**
- ▶ When installing a valve, provide an appropriate valve support so that excessive force is not applied to the valve and piping.
- ▶ Always use the product within the indicated product specifications.
- ▶ Keep the ambient temperature of the installation location within -10 to 50° C.
- ▶ Avoid locations with volatile gases or poor atmospheres. Provide a cover, etc., to cover the entire area.

3. Name of parts

Size: 15~50mm

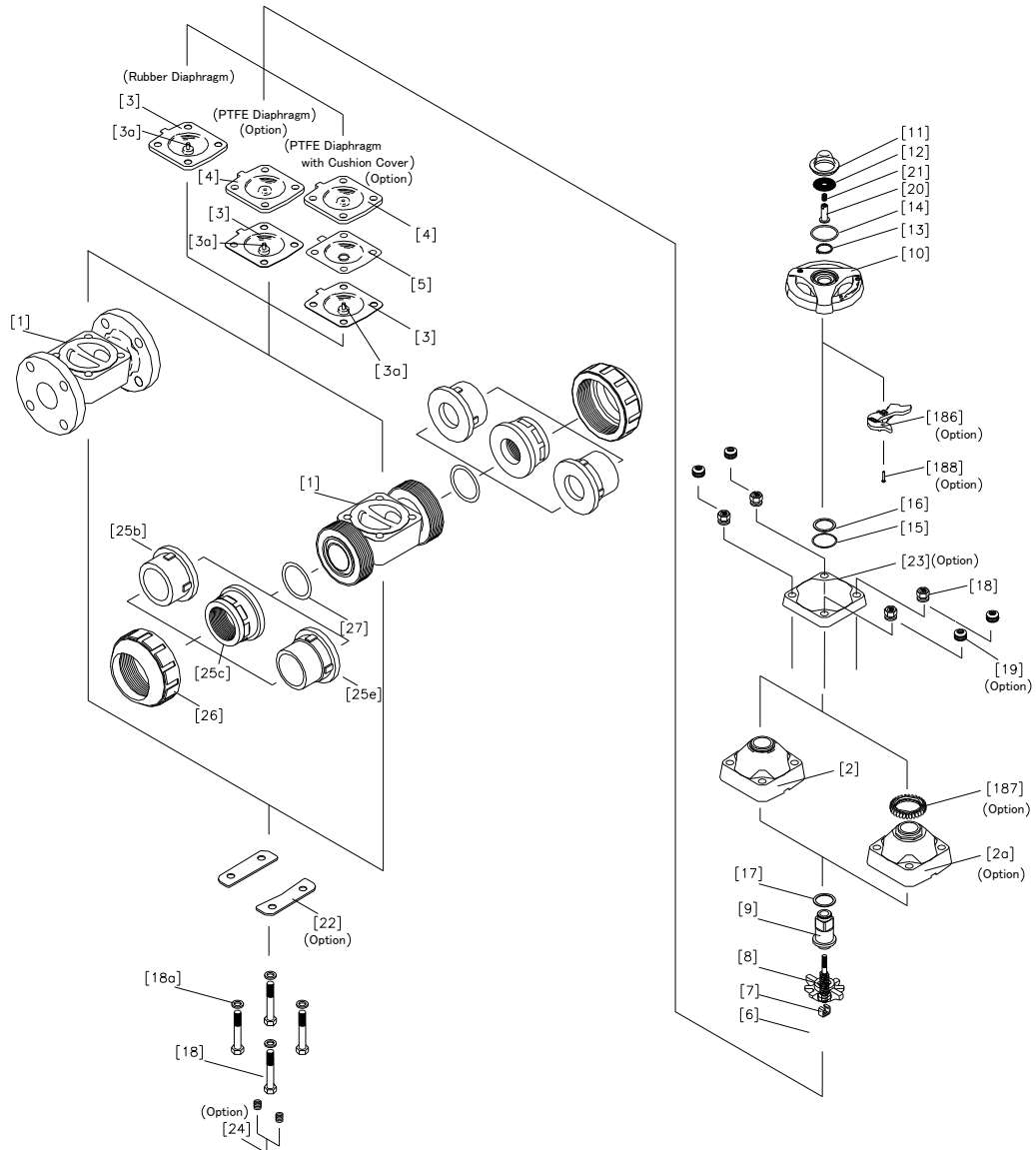

No.	DESCRIPTION	No.	DESCRIPTION	No.	DESCRIPTION
[1]	Body	[11]	Gauge cover	[22]	Body liner
[2]	Bonnet	[12]	Nameplate	[23]	Liner
[2a]	Bonnet(for handle lock)	[13]	Retaining Ring C-Type	[24]	Metal Insert (Ensat)
[3]	Diaphragm	[14]	O-ring (A)	[25b]	End Connector (socket type)
[3a]	Inserted Metal of Diaphragm	[15]	O-ring (B)	[25c]	End Connector (threaded type)
[4]	Cushion	[16]	Thrust ring (A)	[25e]	End Connector (spigot type)
[5]	Cushion cover	[17]	Thrust ring (B)	[26]	Union Nut
[6]	Compressor	[18]	Bolt/nut (A)	[27]	O-ring (C)
[7]	Joint	[18a]	Washer	[186]	Locking lever
[8]	Stem	[19]	Conical Spring Washer	[187]	Locking plate
[9]	Sleeve	[20]	Stopper	[188]	Tapping screw
[10]	Handle	[21]	Screw		

Size: 65~100mm

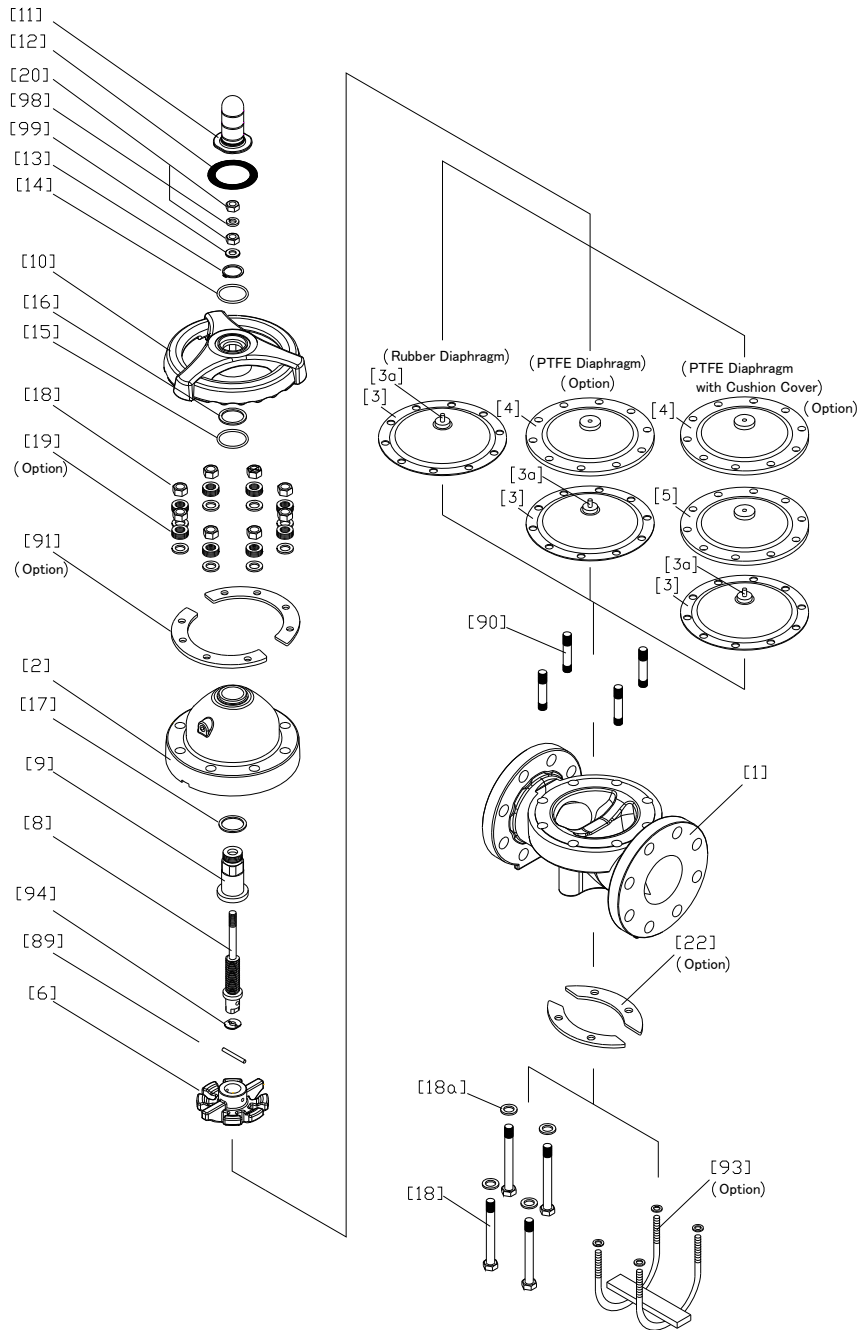

No.	DESCRIPTION	No.	DESCRIPTION	No.	DESCRIPTION
[1]	Body	[11]	Gauge cover	[20]	Stopper
[2]	Bonnet	[12]	Nameplate	[22]	Body liner
[3]	Diaphragm	[13]	Retaining Ring C-Type	[89]	Compressor pin
[3a]	Inserted metal of Diaphragm	[14]	O-ring (A)	[90]	Stud bolt and nut
[4]	Cushion	[15]	O-ring (B)	[91]	Upper Bonnet Liner
[5]	Cushion cover	[16]	Thrust ring (A)	[93]	U-bolt and nut
[6]	Compressor	[17]	Thrust ring (B)	[94]	Metal of Compressor
[8]	Stem	[18]	Bolts and nuts	[98]	Spring Washer
[9]	Sleeve	[18a]	Washer	[99]	Valve seat
[10]	Handle	[19]	Conical spring washer (A)		

4. Product Specifications

Product Model Code List

Actuation	Valve type	Operating system	Body material	Seal material	Connection	Standard	Size	High purity series
V	14	**	*	*	F	*	***	*
V Manual valve	14 Type 14	MH Round handle (Standard) HL with Handle lock (Option) 15-50mm	U U-PVC C C-PVC P PP F PVDF G PVDF+PPG	E EPDM T PTFE V FKM F Viflon F (FKM-F) C Viflon C (FKM-C)	F Flanged	1 JIS 10K D DIN A ANSI (Grinnel standard) J ANSI (AV standard)	015 15mm 020 20mm 025 25mm 032 32mm 040 40mm 050 50mm 065 65mm 080 80mm 100 100mm	Blank Non 1 Lubricant free

Actuation	Valve type	Operating system	Body material	Seal material	Connection	Standard	Size	High purity series
V	T1	**	*	*	*	*	***	*
V Manual valve	T1 True union Type 14	MH Round handle (Standard) HL with Handle lock (Option) 15-50mm	U U-PVC C C-PVC P PP F PVDF G PVDF+PPG	E EPDM V FKM 1 PTFE+EPDM 2 PTFE+FKM	S Socket N Treaded P Spigot	J JIS D DIN A ANSI	015 15mm 020 20mm 025 25mm 032 32mm 040 40mm 050 50mm	Blank Non 1 Lubricant free

- NOTE**
- JIS standard socket type with body material PVDF is not manufactured.
 - JIS standard socket type 32mm with body material of PP is not manufactured.

Relationship between maximum allowable pressure and temperature

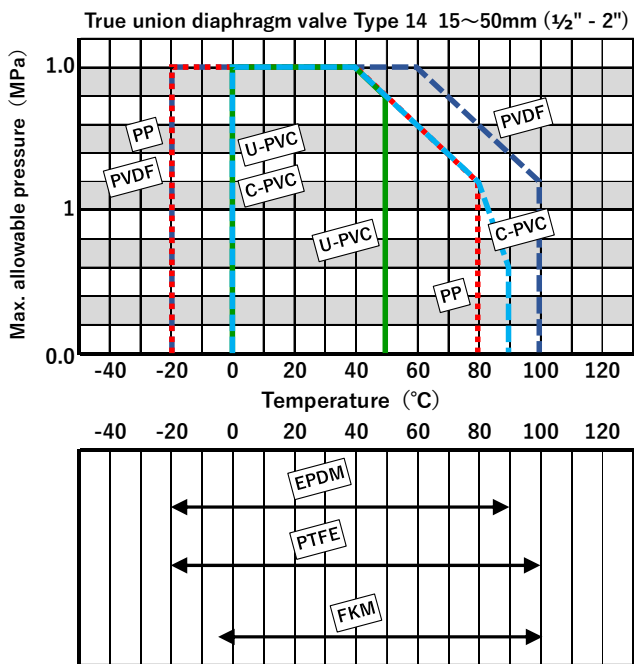
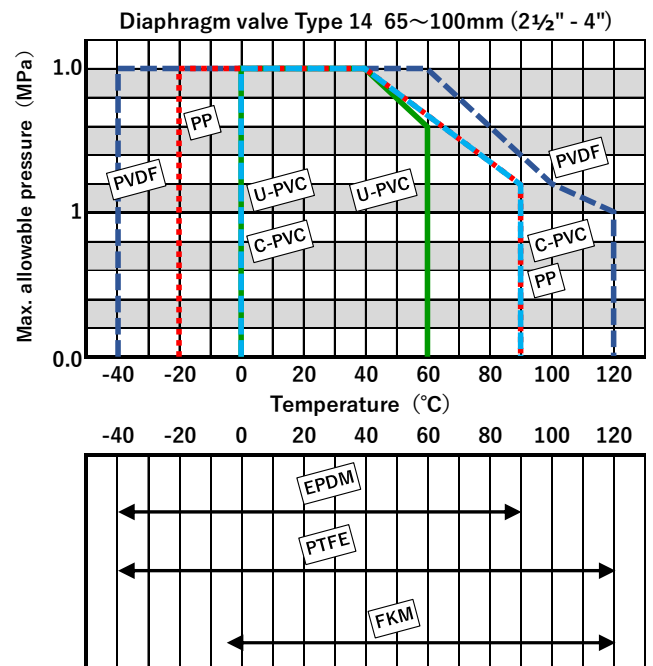
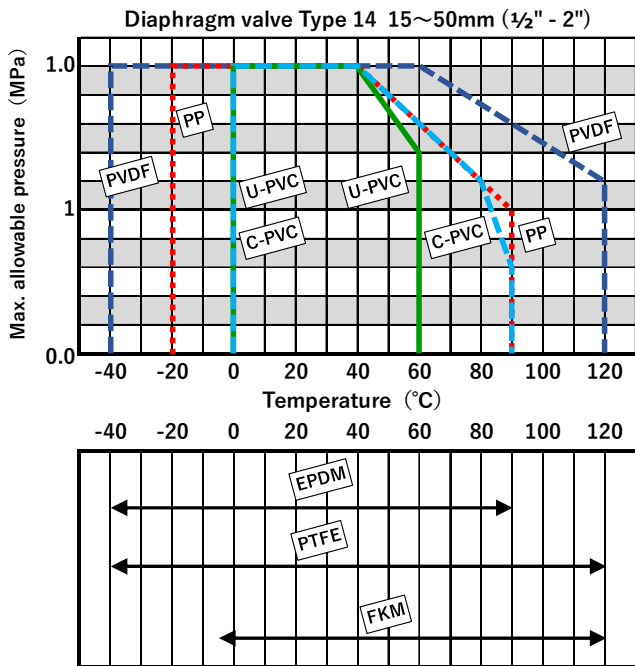

Limit switch specifications

Size (mm)	Model	Switch contact	Protection grade
15 - 100	SL1-A	Silver contact	IP67
	SL1-AK	Gold contact (minute current specification)	

Limit Switch Rated Internal Circuit Diagram

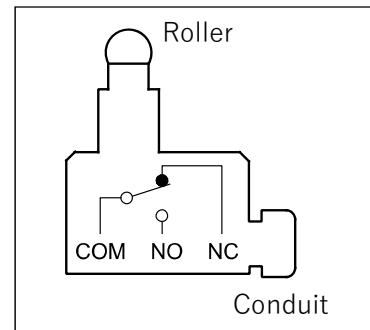

Model code	Rated voltage (V)	Resistance load (A)	Induction load (A)
SL1-A	125AC	5	3
	250AC	5	3
	8DC	5	3
	14DC	5	3
	30DC	5	3
	115DC	0.5	0.1
	DC230	0.25	0.05
SL1-AK	115AC	0.1	-
	8DC	0.1	-
	14DC	0.1	-
	30DC	0.1	-





COM-NO is ON when valve is fully open (and fully closed).

5. Piping method

Flanged end

 Warning	
 Prohibition	<p>Serious injury can result.</p> <ul style="list-style-type: none"> ▶ Hanging and slinging of the valve should be done with full consideration for safety and should not stand beneath the load.

 Caution	
 Prohibition	<p>The valve can be damaged, or leak.</p> <ul style="list-style-type: none"> ▶ Do not overtighten the cap nut. ▶ Do not use a pipe wrench to tighten the cap nut. ▶ Do not tighten the bolts and nuts for piping to the specified torque values in Table 5-2.
 Forcing	<p>There is a danger of injury.</p> <ul style="list-style-type: none"> ▶ Be sure to perform safety inspections of the machine tool and power tool beforehand. ▶ Wear appropriate protective equipment according to the type of work being performed. <p>The valve can be damaged, or leak.</p> <ul style="list-style-type: none"> ▶ Install the product so that excessive stress such as tension, compression, bending or impact is not applied to the piping or valve. ▶ Fix the body cap during piping work or disassembly and reassembly. ▶ When attaching the valve to the end of the pipe, be sure to attach the cap nut and body cap on the secondary side (downstream side). ▶ When connecting to metal piping, do not apply piping stress to the valve. ▶ Use a connection flange with a full-face seat. ▶ Check that there is no difference in mutual flange standards. ▶ Be sure to use a sealing gasket (AV packing) between the flanges and tighten the pipe bolts/nuts to the specified torque values in Table 5-2 "Flange tightening torque." (When other than AV packing, the tightening torque value will change.) ▶ Keep the axis misalignment and parallelism of the flange surface below the values shown in Table 5-1 "Axis misalignment and parallelism." ▶ Tighten the bolts and nuts for piping diagonally with the specified torque values in Table 5-2.

- Preparations
- ▶ Torque Wrench
 - ▶ Spanner or an eyeglass wrench
 - ▶ Belt Wrench
 - ▶ Piping bolts, nuts, and washers
 - ▶ AV packing
 - ▶ Waste cloth

[Procedure]

- 1) Clean mutual flange surfaces with a waste cloth.
- 2) Set AV packing between the flanges.
- 3) Insert the washer and bolt from the connecting flange side, insert the washer and nut from the valve side, and tighten temporarily by hand.
- 4) Set the axis misalignment and parallelism of the flange surface below the values shown in **Table 5-1, "Axis misalignment and parallelism."** (See **Fig. 5-1.**)
- 5) Using a torque wrench, gradually tighten the screws diagonally to **"Table 5-2 Flange Tightening Specified Torque Values"**. (See **Fig. 5-2.**)
- 6) Tighten it more than two turns clockwise with **"Table 5-2 Flange Tightening Torque Specified Values"**. (See **Fig. 5-2.**)
- 7) When it is necessary to loosen or remove the cap nut for construction reasons, follow the procedure below to tighten the cap nut.
 - 7-1) Make sure that the O-ring (A) is installed in the body correctly.
 - 7-2) Bring the body cap and cap nut into contact with the body side so that the O-ring (A) does not come off.
 - 7-3) Tighten the cap nut by hand until it is tight.
 - 7-4) Screw in the cap nut by 1/4 to 1/2 turn with a belt wrench to prevent damage to the cap nut.

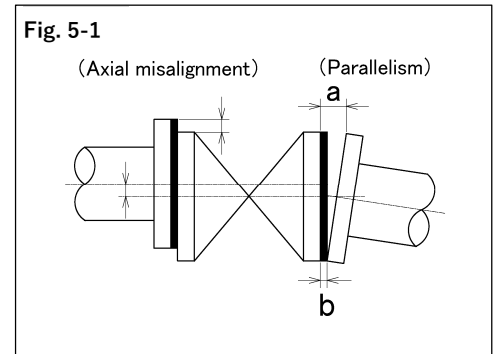

Table 5-1 Axis misalignment and parallelism

Size	Axial misalignment	Parallelism (a-b)
15mm	1.0 mm	0.5 mm
20mm		
25mm		
32mm		
40mm	1.0 mm	0.8 mm
50mm		
65mm		
80mm		
100mm	1.0 mm	1.0 mm

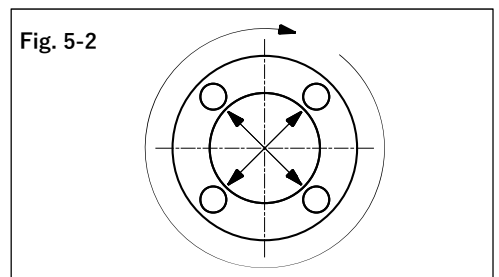







Table 5-2 Flange tightening torque

Size	PTFE coating	PVDF coating	Rubber
15mm	17.5 N-m	17.5 N-m	8.0 N-m
20mm			
25mm	20.0 N-m	20.0 N-m	20.0 N-m
32mm			
40mm			
50mm	22.5 N-m	22.5 N-m	22.5 N-m
65mm			
80mm	30.0 N-m	30.0 N-m	30.0 N-m
100mm			

Threaded end

 Warning	
 Prohibition	<p>Serious injury can result.</p> <ul style="list-style-type: none"> ▶ When hanging or slinging a valve, pay sufficient attention to safety, and do not enter under the load.

 Caution	
 Prohibition	<p>The valve can be damaged, or leak.</p> <ul style="list-style-type: none"> ▶ Do not overtighten the screws at the joints. ▶ Do not overtighten the cap nut. ▶ Do not use a pipe wrench to tighten the cap nut.
 Forcing	<p>There is a danger of injury.</p> <ul style="list-style-type: none"> ▶ Be sure to perform safety inspections of the machine tool and power tool beforehand. ▶ Wear appropriate protective equipment according to the type of work being performed. <p>The valve can be damaged, or leak.</p> <ul style="list-style-type: none"> ▶ The cap nut of this product is lightly tightened to make it easier to loosen. Be sure to remove the body cap before installation. ▶ Install the product so that excessive stress such as tension, compression, bending or impact is not applied to the piping or valve. ▶ Fix the body cap during piping work or disassembly and reassembly. ▶ When attaching the valve to the end of the pipe, be sure to attach the cap nut and body cap on the secondary side (downstream side). ▶ When connecting to metal piping, do not apply piping stress to the valve. ▶ Make sure that the screws at the joints are made of resin. ▶ Use sealing tape for the sealing material of the screw-in part. If liquid sealant or liquid gasket is used, stress cracking (environmental stress cracking) may occur.



Preparations : ▶ Sealing tape ▶ Belt Wrench ▶ Spanner or motor wrench

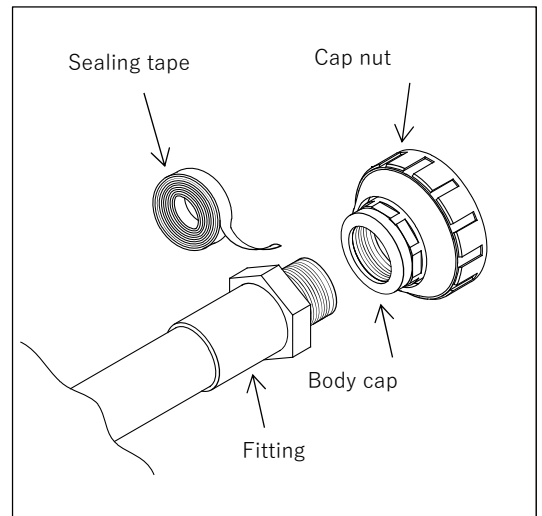

[Procedure]

- 1) Wrap sealing tape around the male thread of the fitting, leaving approximately 3mm at the end.
- 2) Loosen the cap nut by hand.
- 3) Remove the cap nut and body cap from the body.
- 4) Tighten the male thread of the fitting and the body cap until tight.
- 5) Screw in with a wrench or a motor wrench 1/2 to 1 turn to prevent damage to the body cap.
- 6) Check that the O-ring (A) is correctly installed in the body.
- 7) Bring the body cap and cap nut into contact with the body side so that the O-ring (A) does not come off.
- 8) Tighten the cap nut by hand until it is tight.
- 9) Screw in the cap nut by 1/4 to 1/2 turn with a belt wrench to prevent damage to the nut.



Socket end (adhesive)

 Warning	
 Prohibition	<p>Serious injury can result.</p> <ul style="list-style-type: none"> ▶ When hanging or slinging a valve, pay sufficient attention to safety, and do not enter under the load. <p>Fire or an explosion can result.</p> <ul style="list-style-type: none"> ▶ Ensure adequate ventilation when using adhesives and do not use open flames in the surroundings.

 Caution	
 Prohibition	<p>There is a danger of injury.</p> <ul style="list-style-type: none"> ▶ The adhesive contains volatile solvents, so do not inhale odors directly. <p>The valve can be damaged, or leak.</p> <ul style="list-style-type: none"> ▶ Do not apply too much adhesive. Excessive adhesive will flow into the valve. ▶ Do not strike the pipe when inserting it into the body cap. ▶ Do not overtighten the cap nut. ▶ Do not use a pipe wrench to tighten the cap nut.
 Forcing	<p>There is a danger of injury.</p> <ul style="list-style-type: none"> ▶ Be sure to perform safety inspections of the machine tool and power tool beforehand. ▶ Wear appropriate protective equipment according to the type of work being performed. ▶ If the adhesive adheres to the skin, remove it immediately. ▶ If you feel worse or feel unusual when using the adhesive, promptly seek a doctor's diagnosis and take appropriate action. <p>The valve can be damaged, or leak.</p> <ul style="list-style-type: none"> ▶ The cap nut of this product is lightly tightened to make it easier to loosen. Be sure to remove the body cap before installation. ▶ Install the product so that excessive stress such as tension, compression, bending or impact is not applied to the piping or valve. ▶ Fix the body cap during piping work or disassembly and reassembly. ▶ When attaching the valve to the end of the pipe, be sure to attach the cap nut and body cap on the secondary side (downstream side). ▶ Be careful when constructing under low temperature, as solvent vapor is less likely to evaporate and tends to remain. ▶ After piping, open both ends of the pipe and use a blower (low-pressure type) to ventilate to remove the solvent vapor. ▶ Use "ASAHI AV adhesive" depending on the material. ▶ Perform the water flow test after 24 hours or more have elapsed after completion of bonding.

Preparations : ▶ ASAHI AV glue ▶ Belt Wrench ▶ Waste cloth

[Procedure]

- 1) Loosen the cap nut by hand.
- 2) Remove the cap nut and body cap from the body.
- 3) Pass the cap nut to the pipe side.
- 4) Wipe off the insertion part of the pipe and the socket part of the body cap with a waste cloth.
- 5) Refer to "Table 5-3 Adhesive Consumption (Reference)" and apply adhesive evenly in the order of the socket part of the body cap and the pipe insertion part.
- 6) After applying the adhesive, quickly insert the pipe into the body cap and hold it as is for at least 60 seconds.

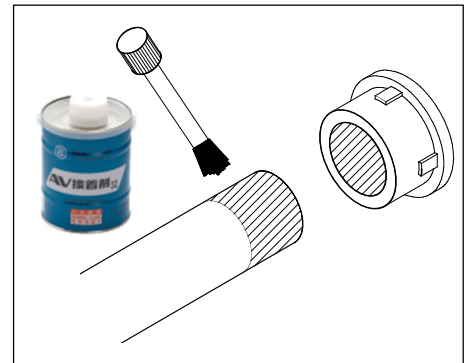







Table 5-3. Usage of adhesives (reference)

Nominal size	Volume used
15mm	1.0 g
20mm	1.3 g
25mm	2.0 g
32mm	2.4 g
40mm	3.5 g
50mm	4.8 g
65mm	6.9 g
80mm	9.0 g
100mm	13.0 g

Socket end, Spigot end (fusing)

 Warning	
 Prohibition	<p>Serious injury can result.</p> <ul style="list-style-type: none"> ▶ When hanging or slinging a valve, pay sufficient attention to safety, and do not enter under the load.

 Caution	
 Prohibition	<p>The valve can be damaged, or leak.</p> <ul style="list-style-type: none"> ▶ Do not overtighten the cap nut. ▶ Do not use a pipe wrench to tighten the cap nut.
 Forcing	<p>There is a danger of injury.</p> <ul style="list-style-type: none"> ▶ Be sure to perform safety inspections of the machine tool and power tool beforehand. ▶ Wear appropriate protective equipment according to the type of work being performed. <p>The valve can be damaged, or leak.</p> <ul style="list-style-type: none"> ▶ The cap nut of this product is lightly tightened to make it easier to loosen. Be sure to remove the body cap before installation. ▶ Install the product so that excessive stress such as tension, compression, bending or impact is not applied to the piping or valve. ▶ Fix the body cap during piping work or disassembly and reassembly. ▶ When attaching the valve to the end of the pipe, be sure to attach the cap nut and body cap on the secondary side (downstream side).



Preparations	▶ Belt Wrench	▶ Welding machine	▶ Instruction manual of the welding machine
--------------	---------------	-------------------	---------------------------------------------

[Procedure]

- 1) Loosen the cap nut [26] with a belt wrench.
- 2) Remove cap nut [26] and body cap [25b].
- 3) Thread the cap nut [26] to the pipe side.
- 4) Perform fusion. (Refer to the manual of the welding machine.)
- 5) After completing the welding, check that the O-ring (C) [27] is installed.
- 6) Contact the body cap [25b] and the cap nut [26] with the O-ring (C) [27] so that they will not come off.
- 7) Tighten the cap nut [26] by hand until it is tight.
- 8) Screw the cap nut [26] 1/4 to 1/2 turn with a belt wrench to avoid damage.

Limit switch wiring method

 Warning	
 Prohibition	<p>Serious injury can result.</p> <ul style="list-style-type: none"> ▶ Do not connect or separate lines to the limit switch in the power supply status.

 Caution	
 Prohibition	<p>Doing so may cause a malfunction.</p> <ul style="list-style-type: none"> ▶ Do not leave or use with the cover open. (Water or dust may penetrate and cause operation failure.)
 Forcing	<p>Otherwise failure or malfunction can result.</p> <ul style="list-style-type: none"> ▶ Connect the wires using solderless terminals with insulation covering so that they do not come into contact with the cover or housing. (If the crimp terminal comes into contact with the cover, the cover may not tighten or a ground fault may occur.) ▶ Securely attach the cover. (Rainwater may enter and cause malfunction.)

- Preparations
- ▶ Phillips screwdriver
 - ▶ Flat-blade screwdriver
 - ▶ Connector (G1/2)
 - ▶ Wire stripper
 - ▶ Terminal crimping tool

[Procedure]

- 1) Process the end of the cable as shown in the right figure.
- 2) Attach the crimp terminal to the end of the lead wire.
Use M3 round crimp terminals with insulated sleeves.
(Bare solderless terminals may cause a short circuit.)
- 3) Remove the terminal cover from the housing with a flathead screwdriver.
- 4) Cable as shown below. Cap nut, washer, seal, terminal cover
Thread in the order shown.

Cable end processing dimensions

Grommet contact area
(Take care not to damage the surface.)

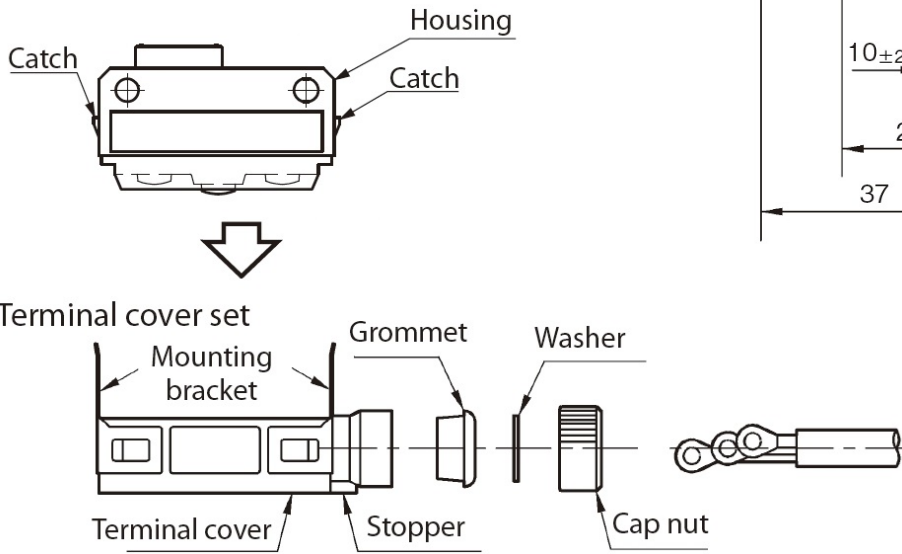
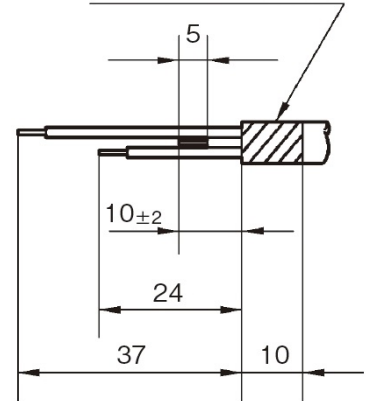

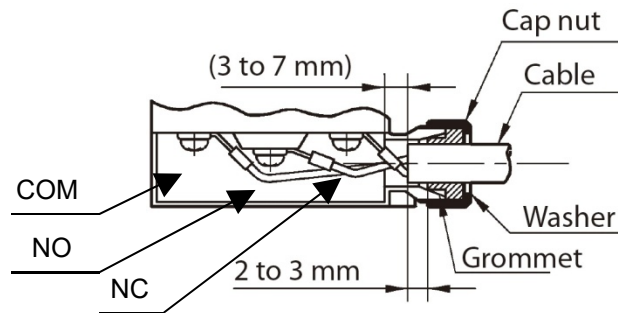

- 5) Connect the crimp terminal to the terminal by referring to the figure below.

Example of standard connection



- 6) Attach the terminal cover to the housing with one touch.
Confirm that the mounting bracket of the terminal cover is securely held by the claw of the housing.
- 7) Tighten the cap nut to secure the cable.

6. Mounting method of the Ensats and the frame (panel)

 Caution	
 Prohibition	<p>The valve can be damaged, or leak.</p> <ul style="list-style-type: none"> ▶ Do not over-tighten when supporting piping with a U-band, etc. ▶ When installing a valve in the piping around the pump, do not cause large vibrations in the valve.
 Forcing	<p>There is a danger of injury.</p> <ul style="list-style-type: none"> ▶ Be sure to perform safety inspections of the machine tool and power tool beforehand. ▶ Wear appropriate protective equipment according to the type of work being performed. <p>The valve can be damaged, or leak.</p> <ul style="list-style-type: none"> ▶ Do not over-tighten when supporting piping with a U-band, etc. ▶ Install it vertically when screwing in the Ensats. ▶ For detailed handling of the special tool for installation of the Ensats, refer to the instruction manual of the Ensats manufacturer separately.

► Attach the embossing (commercially available) to the bottom stand

[Procedure]

Refer to the instruction manual of the entertainment (commercially available).

Bottom Stand and Ensat Dimensions

Unit; mm

Size(mm)	S	S1	S2
15~32	25	7	13
40、 50	45	9	15
65	85	11	20
80	100	15	28
100	120	15	28

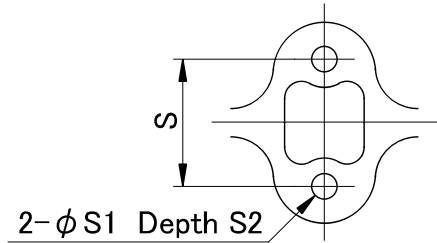

Size(mm)	Nominal thread	Length (mm)	Material
15~32	M5	10	Brass (CuZn39Pb3)
40、 50	M6	14	Brass (CuZn39Pb3)
65	M8	15	Brass (CuZn39Pb3)
80	M12	22	Brass (CuZn39Pb3)
100	M12	22	Brass (CuZn39Pb3)

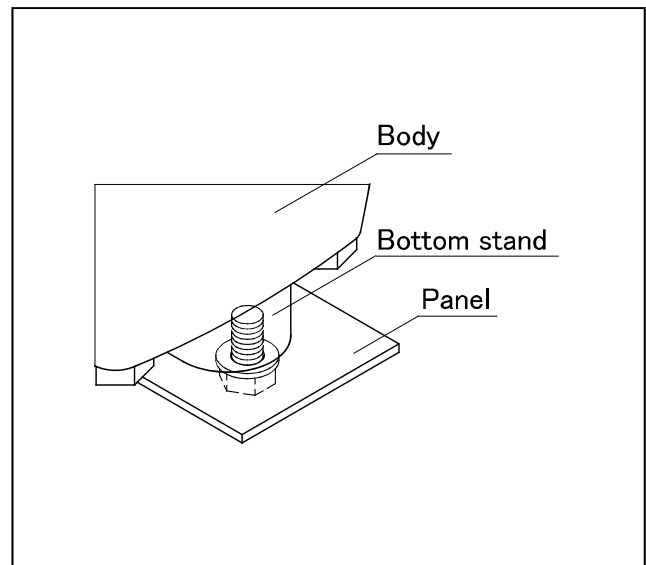
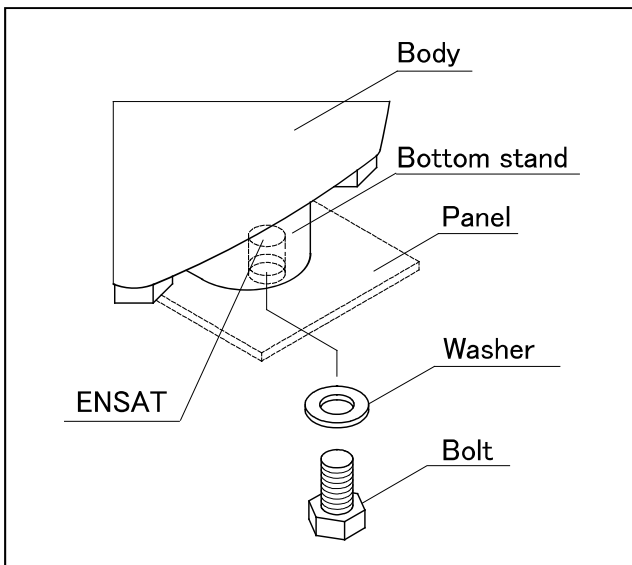

Ensats[®] manufacturer: K.K.V. Corporation

► Fastening the Bottom Stand to the Panel



7. Operating procedure

Valve opening and closing operations

 Caution	
 Prohibition	<p>The valve can be damaged, or leak.</p> <ul style="list-style-type: none"> ▶ Do not turn the handle unnecessarily with excessive force when fully closing or opening the valve. ▶ Do not open or close the valve with dust or other foreign matter in the fluid.
 Forcing	<p>The valve can be damaged, or leak.</p> <ul style="list-style-type: none"> ▶ Since foreign matter such as sand may remain in the pipeline even after the valve is installed, open and close the valve after cleaning the inside of the pipe. ▶ Handle operation must be done by hand. (Use of equipment may cause damage.) ▶ Be sure to pass water before opening/closing the oil-prohibited parts. ▶ If the stopper is loose, adjust the stopper.

▶ Quietly turn the handle to open or close it.
(Clockwise to close-"Handle display S"; counterclockwise to open-"Handle display O".)

▶ When fully closed, the end of the stopper is hidden by the nameplate.

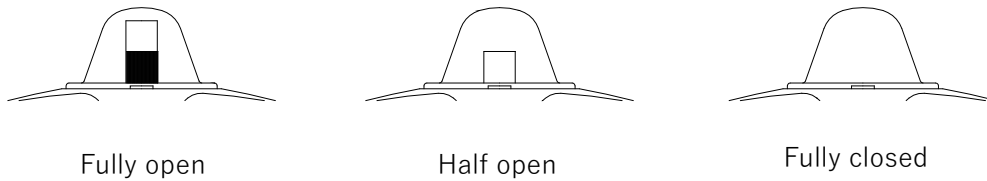

<For 15~50mm>

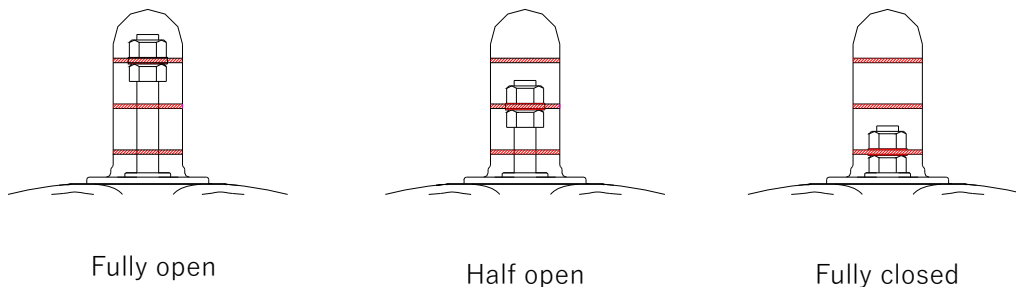

<For 65~100mm>



Operating procedure of locking device

 Caution	
 Prohibition	<p>The valve can be damaged, or leak.</p> <ul style="list-style-type: none"> ▶ C, while locked Do not turn the doll with excessive force. ▶ Do not disassemble the handle.
 Forcing	<p>The valve can be damaged, or leak.</p> <ul style="list-style-type: none"> ▶ When locking to prevent accidental operation, use a padlock, etc. ▶ The valve is shipped with the simple lock engaged. Release the lock before operating the valve.

- 1) Push the Lock Release Lever with the padlock holes to unlock.
- 2) Turn the handle to the desired opening.
- 3) Push the Lock Lever without the padlock holes to engage the Lock.
- 4) A padlock hole is provided on the locking lever to prevent accidental operation. If necessary, use a lock to lock the product. (See Table 1 for padlock sizes.)

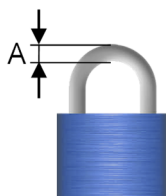
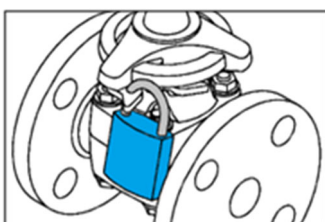
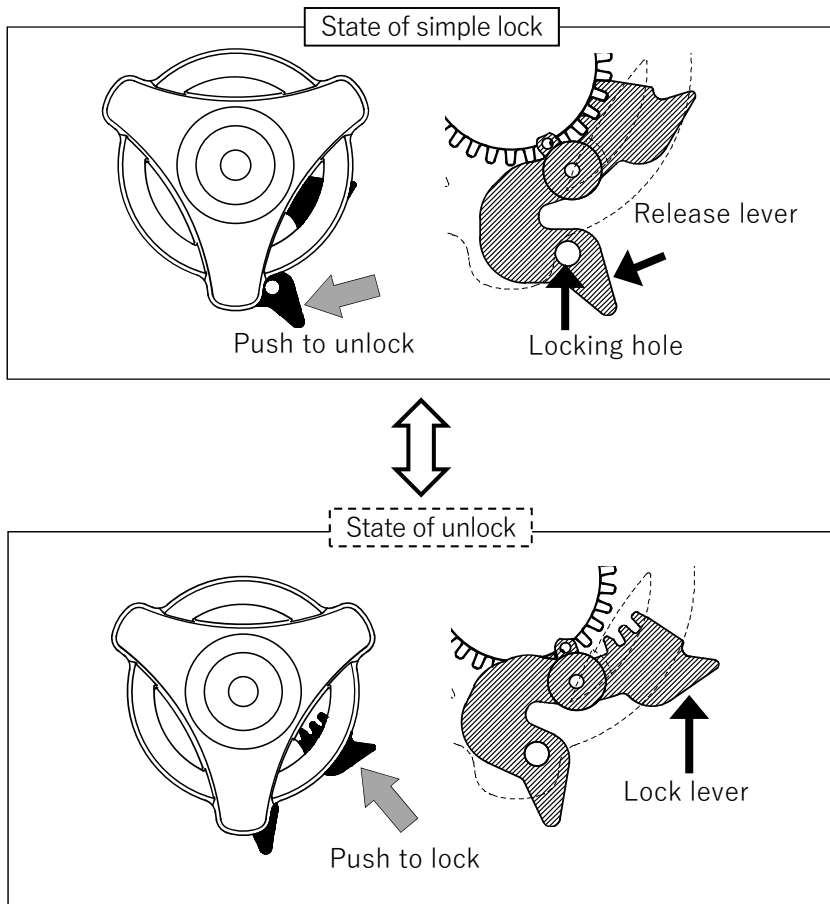

Table 1 Padlock size

SIZE (mm)	A
15~32	5mm
40~50	6mm

8. Adjustment procedure for stopper

⚠ Caution

! Forcing

The valve can be damaged, or leak.

- ▶ If the stopper is loose or internal leakage occurs when the valve is fully closed, the stopper may not be functioning. Adjust the stopper.
- ▶ Tighten the stopper securely.
(If the tightening torque of the stopper is insufficient, the stopper may become loose.)

Preparations

- ▶ Spanner ▶ Allen key (15~50mm) ▶ Protective gloves ▶ Protective glasses
- ▶ Flat-head screwdriver (sometimes required to remove gauge cover) (15~50mm)

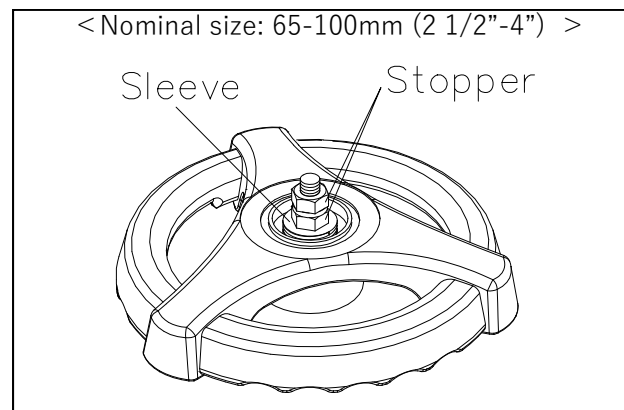
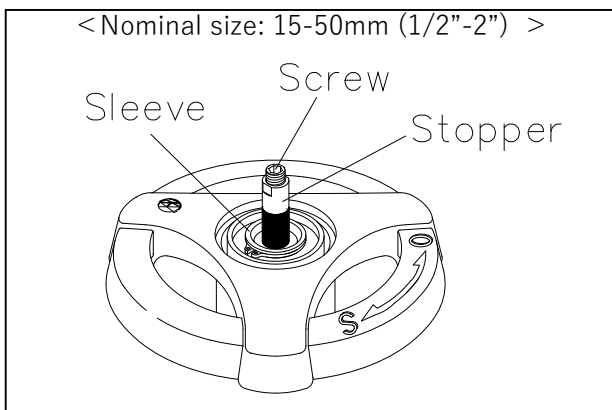

Adjusting Stopper <For 15~50mm>

- ① Remove the gauge cover.
(Be careful not to damage the O-ring.)

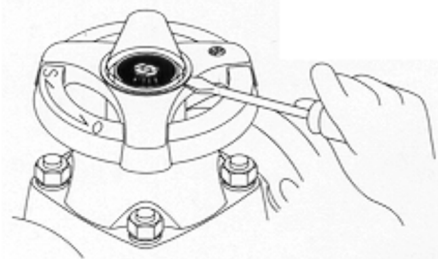

- ⑤ Screw the stopper to the position where the flange comes into contact with the step inside the sleeve. Then, turn the stopper a half turn back.



- ② Fix the stopper and loosen the set screw.

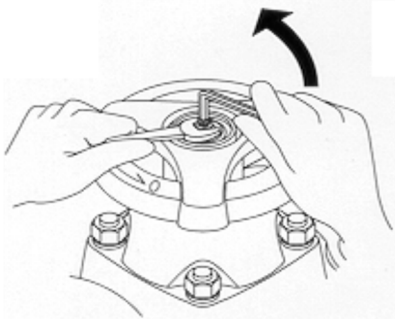

- ⑥ Fix with a wrench and tighten the set screw to the specified torque value (see the table below).

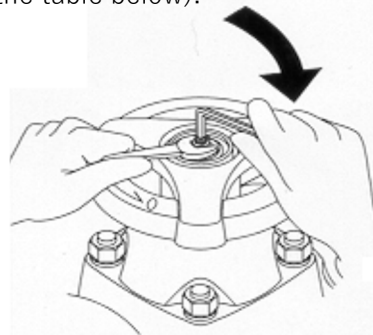

- ③ Loosen the stopper.

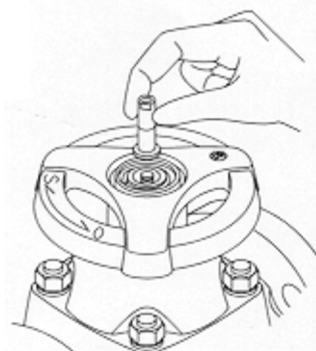

- ⑥ Fit the gauge cover.

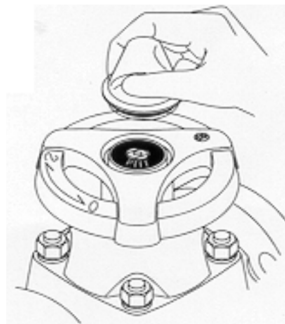

- ④ Tighten the handle gradually until it stops at a point where liquid leakage stops.

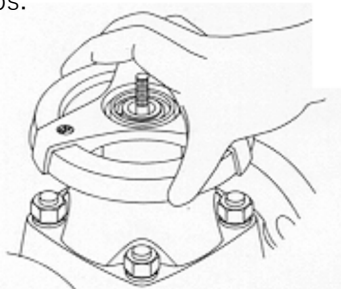

Tightening torque of set screw

	Units: N·m	
Size	15-32mm	40, 50mm
Torque value	8.0	12.0

Adjusting Stopper <For 65~100mm>

[Procedure]

- 1) Remove gauge cover [11] by turning it counterclockwise.
- 2) Secure lower nut [20] and loosen upper nut [20].
- 3) Loosen the stopper (nut) [20].
- 4) Gradually tighten the handle [10] until it stops at a point where the fluid leaks.
- 5) Screw in the stopper (nut) [20] until it comes into contact with the upper surface of the sleeve [9].
- 6) Then, turn the stopper [20] a half turn back.
- 7) Secure and tighten the stopper (nut) [21] with a wrench.
- 8) Fit gauge cover [11].

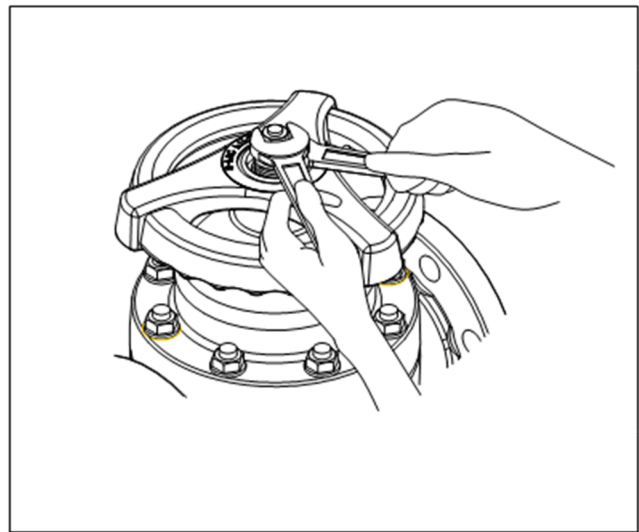
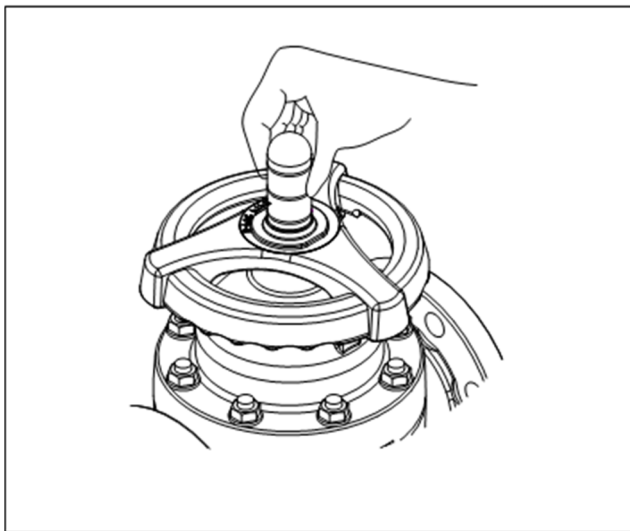

Stopper tightening torque

Units: N-m

Size	Tightening torque
65~100mm	15.0

9. Diaphragm replacement procedure

 **Warning**

 **Forcing**

There is a danger of injury.

- ▶ Be sure to perform safety inspections of the machine tool and power tool before starting operation.
- ▶ Wear appropriate protective equipment for the work details when installing piping.

 **Caution**

 **Prohibition**

The valve can be damaged, or leak.

- ▶ When replacing the valve or replacing parts, completely drain the fluid from the piping to reduce the fluid pressure to zero.

Preparations ▶ Torque wrench ▶ wrench (2 pcs) ▶ Protective gloves ▶ Protective glasses

[Procedure]

- 1) Completely loosen bolts and nuts [18] [90] between body [1] and bonnet [2].
- 2) Remove the bonnet section.
- 3) Turn handle [10] to fully close valve.
(It may be difficult to work when fully opened)

4) When the diaphragm mounting structure is a bayonet type

NOTE) Standard is bayonet type.

Remove the diaphragm [3] by rotating it 90 degrees. Install the new diaphragm in the reverse order.
Match the material indicator part of the diaphragm [3] (and cushion [4]) with the cutout part of the bonnet [2].

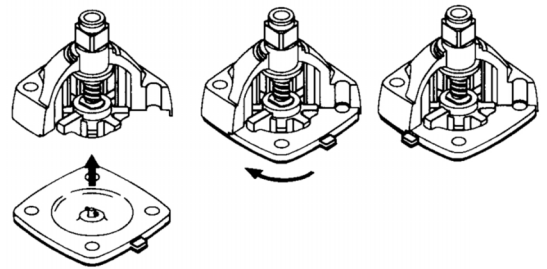

Diaphragm mounting structure is screw type

Remove the diaphragm [3] by rotating it counterclockwise (left).

Install the new diaphragm in the reverse order.

Match the material indicator part of the diaphragm [3] (and cushion [4]) with the cutout part (valve seat direction) of the bonnet [2]. Also, check if the diaphragm embedded metal fitting [3a] is screwed in completely.

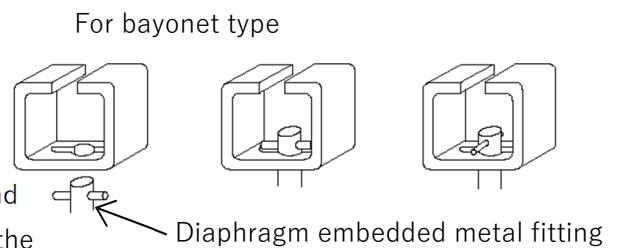

※ Standard is bayonet type.

If it is difficult to mount with a PTFE diaphragm, reverse the diaphragm [3] before mounting. Check whether the pin of the embedded metal fitting [3a] of the diaphragm is completely engaged with the joint metal fitting [5] (compressor metal fitting [94]).

(If the connection is incomplete, it may become impossible to open and close.)

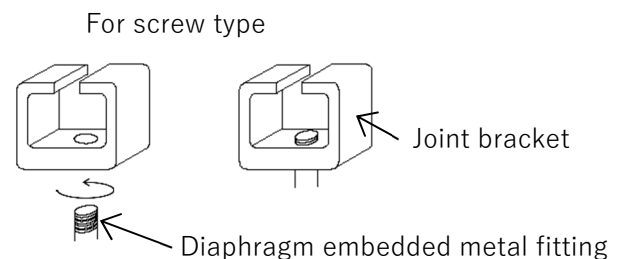

NOTE) The diagram shows the nominal diameter 15~50mm.
Bayonet type is standard, screw type is electrolytic specification.



- 5) Attach the bonnet [2] in the reverse order of 2).
- 6) Turn handle [10] one turn in the opening direction.
- 7) Tighten the bolts and nuts [18] and [90] between the body [1] and the bonnet [2] to the "bonnet tightening torque value" with a torque wrench in a diagonal line.
- 8) Tighten the bonnet in a clockwise direction with a tightening torque value of 2 turns or more.
- 9) Adjust the stopper.

Bonnet tightening torque value

Units;N•m{kgf•cm}

Nominal size Diaphragm	15,20mm	25,32mm	40mm	50mm	65mm	80mm	100mm
Rubber	3 {31}	5 {51}	12 {122}	15 {153}	13 {133}	18 {184}	35 {357}
PTFE	5 {51}	8 {82}	15 {153}	20 {204}	15 {153}	20 {204}	40 {408}

10. Inspection items

 Caution	
 Forcing	<p>The valve can be damaged, or leak.</p> <ul style="list-style-type: none"> ▶ Maintenance should be performed every 3 to 6 months as a guide in order to keep the watch in normal condition and use it for a long time. Pay particular attention to temperature changes and aging during long-term storage or shutdown or use. ▶ When removing the valve from the piping when replacing the valve or parts, completely remove the fluid from the piping before starting work. ▶ If any trouble is found, take the appropriate action referring to "11. Cause of malfunction and remedy"

Daily inspection

Inspection items and inspection methods	Guideline of judgment	Check point	Treatment method
External leakage (visual inspection)	No leakage	[Flanged end] Pipe flange connection	① Retighten the pipe bolts to the specified torque. ② Remove the valve from the pipe and re-tighten the pipe bolts. (Ref: 8. Mounting method [Flanged end])
		[Socket end] Adhesive construction section	Remove the valve from the piping and retry the bonding process. (Ref: 8. Mounting [Socket end])
		[Treaded end] Threaded connection	Remove the valve from the piping and screw the valve in again. (Ref: 8. Mounting method [Threaded end])
		Between the body and bonnet	Retighten the mounting bolts with the specified torque value for bonnet tightening.
		Cap nut portion of the valve	① Retighten the cap nut ② Remove the valve from the piping, check the O-ring and sealing surface, and replace the defective part. (Ref.: 8. Mounting method)
		Surface of the entire valve	Remove the valve from the pipe and replace the valve.
Internal leakage (visual and measurement)	No leakage	Leakage to secondary side when valve is fully closed	Remove the valve from the piping and replace the valve or defective part.
		Measured values of flowmeters, pressure gauges, etc.	Remove the valve from the piping and replace the valve or defective part. (Ref: 10. How to replace the diaphragm)
Abnormal noise (hearing)	No abnormal noise	Valve	Remove the valve from the pipe and replace the valve.
		Piping around the valve	Reconfirm the conditions of use (Ref: 2. Handling Precautions)

Periodic inspection

●Guideline for the inspection cycle: 3 months

Inspection items and inspection methods	Guideline of judgment	Check point	Remedy for malfunctions
Vibration (palpation)	No different from other parts	Valve	Recheck the operating conditions and remove the source of vibration. (Ref: 2. Safety Precautions [Handling the Product])
		Piping around the valve	Recheck the operating conditions and remove the source of vibration. (Ref: 2. Safety Precautions [Handling the Product])

●Guideline of the inspection cycle: 6 months

Inspection items and inspection methods	Guideline of judgment	Check point	Remedy for malfunctions
Operability of manual handle (touch)	Smooth turning	Manual operation unit	Remove the valve from the pipe and replace the valve.
Looseness of bolts (visual and palpation)	No Loose	Between body and bonnet	Retighten the mounting bolts with the specified torque value for bonnet tightening. (Ref: 10. How to replace the diaphragm)
		[Flange type] For flange piping	Retighten the pipe bolts to the specified torque. (Ref: 8. Mounting [Flange Type])
Corrosion or rust (visual inspection)	No corrosion or rust	Appearance of the product	Remove the valve from the pipe and replace the valve.
Product damage	No scratches, cracks, or deformation	Appearance of the product	Remove the valve from the pipe and replace the valve.

11. Cause of malfunction and remedy

 **Caution**

There is a danger of injury.

- ▶ If any malfunction is found, immediately stop using the product and take appropriate action.
- ▶ When removing the valve from the piping when replacing the valve or parts, completely remove the fluid from the piping before starting work.

Failure phenomenon	Possible cause	Measures and measures
Handle does not turn (cannot turn)	The valve is already fully open (or fully closed).	Rotate the hex wrench in the reverse direction (Ref. 11. Test Run)
	Foreign matter caught in valve	Remove the valve from the piping, disassemble it, and remove foreign matter.
	Piping stress is applied to the valve.	Remove the piping stress
	The torque of the valve has increased due to the effects of the fluid (temperature, components, pressure, etc.)	Reconfirm the conditions of use (Ref: 2. Safety Precautions [Handling the Product])
Idle steering wheel	The diaphragm or stem is damaged.	Remove the valve from the pipe, disassemble it, replace the relevant part, or replace the valve. (Ref: 10. How to replace the diaphragm)
Fluid leaks even when fully closed (internal leak)	High fluid pressure	Use below the maximum allowable pressure (Ref: 2. Safety Precautions [Handling the Product])
	The body or diaphragm is damaged.	Remove the valve from the piping, replace the relevant part, or replace the valve.
	Foreign matter caught in valve	Remove the valve from the piping, disassemble it, and remove foreign matter.
	Piping stress is applied to the valve.	Remove the piping stress
	The part is damaged.	Remove the valve from the piping, replace the relevant part, or replace the valve.
	Adjustment stopper is running	Adjust the stopper (Ref: 9. How to adjust the stopper)

Cause of malfunction and remedy (Continue)

Failure phenomenon	Possible cause	Measures and measures
Fluid leaks from valve (external leak)	Valve is cracked or broken	Stop using the product immediately, remove the valve from the piping, and replace the valve.
	Bonnet tightening bolt is loose	Retighten the mounting bolts with the specified torque value for bonnet tightening. (Ref: 10. How to replace the diaphragm)
	The diaphragm is damaged.	Stop using the valve immediately. Remove the valve from the piping and replace the diaphragm or valve. (Ref: 10. How to replace the diaphragm)
	Cap nut is loose	Retighten the cap nut (Ref.: 8. Mounting method)
	O-ring is scratched, worn, melted, or altered	Stop using the product immediately, remove the valve from the piping, replace the relevant part, or replace the valve.
	Scratches or wear are found on the sliding or fixing surfaces of the O-ring.	Stop using the product immediately, remove the valve from the piping, replace the relevant part, or replace the valve.
Valve is corroded or deformed	The watch is exposed to water, chemical liquids, or other liquids.	Stop using the product immediately, remove the valve from the piping, and replace the valve. (Ref: 14. How to disassemble for parts replacement)

12. Handling of residual and waste materials

 Warning	
 Forcing	<p>When burnt, toxic gas is generated.</p> <p>▶ When disposing of the product or parts, please dispose of them according to the guidelines of each local authority by a professional disposal company.</p>

Contact

Contact the nearest dealer, our sales office, or our web website for inquiries about this product.

[User's Manual]

Diaphragm valve Type 14
True union diaphragm valve Type 14



<https://www.asahi-yukizai.co.jp/en>

Please note that the content of this manual is subject to change without notice.

March 2024

[User's Manual] Diaphragm Valve Type 14 / True union Diaphragm Valve Type 14