

# Butterfly valve type 58

## Side gear type

### 700~900mm

## User's Manual



Thank you for choosing our product.

This User's manual contains important information for safe use of our product, so please be sure to read it before handling the product. After reading this manual, please be sure to keep it in a place where the user can see it at any time.

## ASAHI YUKIZAI CORPORATION

**-SAFETY PRECAUTIONS-**



This User's manual is written on the assumption that the person who handles our products has a basic knowledge of our products, electrical equipment, machinery, control, etc., and it contains technical terms depending on the handling contents.

Please read this manual carefully and fully understand the contents and observe the safety precautions for proper use.



In this manual, the warning, caution, prohibition, and enforcement are categorized together with the symbol to inform the situation and scale of human injury or property damage.

Failure to observe this precaution may result in unexpected failure or damage. Be sure to observe this precaution.

**<WARNING/CAUTION indications>**

 <b>Warning</b>	Indicates a potentially hazardous situation which, if not avoided, could result in death or serious injury.
 <b>Caution</b>	Indicates a potentially hazardous situation which, if not avoided, may result in minor or moderate injury or property damage.

**<Prohibited/Forced display>**

 <b>Prohibition</b>	In the handling of the product, it is prohibited to do it in "Do not do it".
 <b>Forcing</b>	In the handling of the product, it is forced by "contents to be carried out without fail".

## Table of contents

<b>1. Our product warranty coverage</b> .....	<b>4</b>
Applicable to .....	4
Warranty Period.....	4
Guaranteed range.....	4
Disclaimer.....	4
<b>2. Safety Instructions</b> .....	<b>5</b>
Unpacking, Transportation and Storage.....	5
Product Handling.....	6
<b>3. Name of each part</b> .....	<b>8</b>
<b>4. Product Specifications</b> .....	<b>9</b>
Model number table.....	9
Relationship between maximum allowable pressure and temperature .....	9
<b>5. Mounting method</b> .....	<b>10</b>
<b>6. Support installation method</b> .....	<b>14</b>
<b>7. Operation method</b> .....	<b>15</b>
<b>8. Water flow and adjusting the stopper of the gear box</b> .....	<b>16</b>
<b>9. Inspection item</b> .....	<b>17</b>
Daily inspection .....	17
Periodic inspection.....	18
<b>10. Cause of malfunction and remedy</b> .....	<b>19</b>
<b>11. Treatment method for residual materials and waste materials</b> .....	<b>21</b>
<b>Inquiries</b> .....	<b>22</b>

## 1. Our product warranty coverage

Unless otherwise stated in the Contract or Specifications, etc., the warranty for the piping material products (hereinafter referred to as "applicable products") such as valves manufactured or sold by us is as follows.

### Applicable to

This warranty applies only when the product is used in Japan. If you intend to use the product overseas, please contact us.

### Warranty Period

The warranty period is one year after delivery.

### Guaranteed range

In the event of failure or malfunction due to our responsibility during the above warranty period, we will replace or repair the product with a substitute free of charge.

Provided, however, that even within the warranty period, the warranty shall not apply to any of the following cases (charged service).



- ▶ When the storage, operating conditions, precautions, etc. described in the specifications, User's manual, etc. are not adhered to in the construction, installation, handling, maintenance, etc.
- ▶ Defects, such as the design of the customer's equipment or software, caused by other than the target product.
- ▶ The fault is due to modification or secondary processing of the product by something other than us.
- ▶ In the case of a failure which can be deemed to have been avoided if the periodic inspection described in the User's manual, etc. or the maintenance or replacement of consumable parts has been performed normally.
- ▶ The component is used for purposes other than the product's intended use.
- ▶ Failure or malfunction due to causes that could not be foreseen by our level of science and technology at the time of shipment.
- ▶ The fault is due to an external factor that is not our responsibility, such as natural disaster or disaster.



### Disclaimer

- ▶ The warranty will not cover secondary damage (damage to equipment, loss of opportunity, loss of profit, etc.) or any other damage caused by the failure of our product.
- ▶ Although we strive to improve the quality and reliability of our products, we do not guarantee their integrity. Especially when using this product for equipment that may infringe human life, body or property, take appropriate safety design measures, etc., with full consideration of problems that may normally occur. We assume no responsibility for such use if we have not obtained our consent in advance in writing of specifications, etc.
- ▶ Please observe the product specifications and precautions when using our products. We shall not assume any responsibility for any damage to the customer caused by the customer's negligence. However, this does not apply to damage caused by a defect in our product.

**2. Safety Instructions**

**Unpacking, Transportation and Storage**

 <b>Warning</b>	
 <b>Forcing</b>	<p><b>Serious injury can result.</b></p> <ul style="list-style-type: none"> <li>▶ When hanging or slinging a valve, pay sufficient attention to safety, and do not enter under the load.</li> </ul>

 <b>Caution</b>	
 <b>Prohibition</b>	<p><b>The valve can be damaged, or leak.</b></p> <ul style="list-style-type: none"> <li>▶ Do not subject the product to impact by throwing, dropping or hitting.</li> <li>▶ Do not scratch or pierce the product with a sharp object such as a knife or hand hook.</li> <li>▶ Avoid contact with coal tar, creosote (a wood preservative), white pesticides, insecticides, paints, etc.</li> <li>▶ Do not hang the handle when transporting the valve.</li> </ul>
 <b>Forcing</b>	<p><b>The valve can be damaged, or leak.</b></p> <ul style="list-style-type: none"> <li>▶ Keep in cardboard until just before piping, and store indoors (at room temperature) away from direct sunlight. Also, avoid storing the product in places of high temperature. (The strength of cardboard packaging decreases when it gets wet. Be very careful when storing and handling it.)</li> <li>▶ After unpacking, make sure that the product is correct and that it meets the specifications.</li> <li>▶ Clean the inner surface of the valve with a clean cloth after removing the product from the packing material.</li> </ul>



 **Warning** **Forcing****Serious injury can result.**

- ▶ Do not disassemble or modify the valve or gear box.
- ▶ If positive pressure gas is used for our resin piping material, a dangerous condition may occur due to the repulsive force peculiar to compressible fluids even if the pressure is the same as the water pressure. Therefore, be sure to take safety measures for the surrounding area, such as covering the piping with protective materials. If you have any questions, please contact us separately.
- ▶ When conducting a pipe leak test after completion of piping construction, be sure to check with water pressure. Contact us in advance if you are unavoidable to test with a gas.

**There is a danger of injury.**

- ▶ Ensure sufficient space for maintenance and inspection.

 **Caution**

<p> <b>Prohibition</b></p>	<p><b>The valve can be damaged, or leak.</b></p> <ul style="list-style-type: none"> <li>▶ Do not step on the valve or place heavy objects on it.</li> <li>▶ Keep away from fire and hot objects.</li> <li>▶ Do not subject the valve to large vibrations.</li> <li>▶ Read the User's manual carefully and fully understand the installation, operation, adjustment, and inspection of the product before starting installation.</li> <li>▶ When used with a high temperature fluid, the misalignment of the valve and flange shaft may cause sheet damage. Exercise due caution when installing the valve.</li> <li>▶ Use a connection flange with a full-face seat. If a flange other than the full face seat (flange adapter/backing flange, etc.) is unavoidably used, the flange corners may bite into the seat depending on the size of the valve, causing damage to the seat. Contact us in advance.</li> </ul>
<p> <b>Forcing</b></p>	<p><b>The valve can be damaged, or leak.</b></p> <ul style="list-style-type: none"> <li>▶ Keep the pressure and temperature of the fluid within the allowable range. (The maximum allowable pressure includes water hammer pressure.)</li> <li>▶ Pay attention to the atmosphere where the valve is installed. Especially, avoid installing the product where it is exposed to sea breezes, corrosive gas, chemical liquids, sea water, steam, etc.</li> <li>▶ Use a valve of suitable material for the operating conditions. (Depending on the type of chemical liquid, the parts may be damaged. Contact us in advance for details.)</li> <li>▶ Use fluids containing crystalline material under conditions that do not recrystallize.</li> <li>▶ Avoid any place where the valve is constantly exposed to splashes of water and dust, or direct sunlight, or protect the valve with a cover or the like to cover the entire area.</li> <li>▶ 「9. Perform maintenance on a regular basis referring to "Inspection items." Pay particular attention to temperature changes and aging during long-term storage or shutdown or use.</li> <li>▶ When installing a valve, provide an appropriate valve support so that excessive force is not applied to the valve and piping.</li> <li>▶ Always use the product within the indicated product specifications.</li> </ul>

### 3. Name of each part

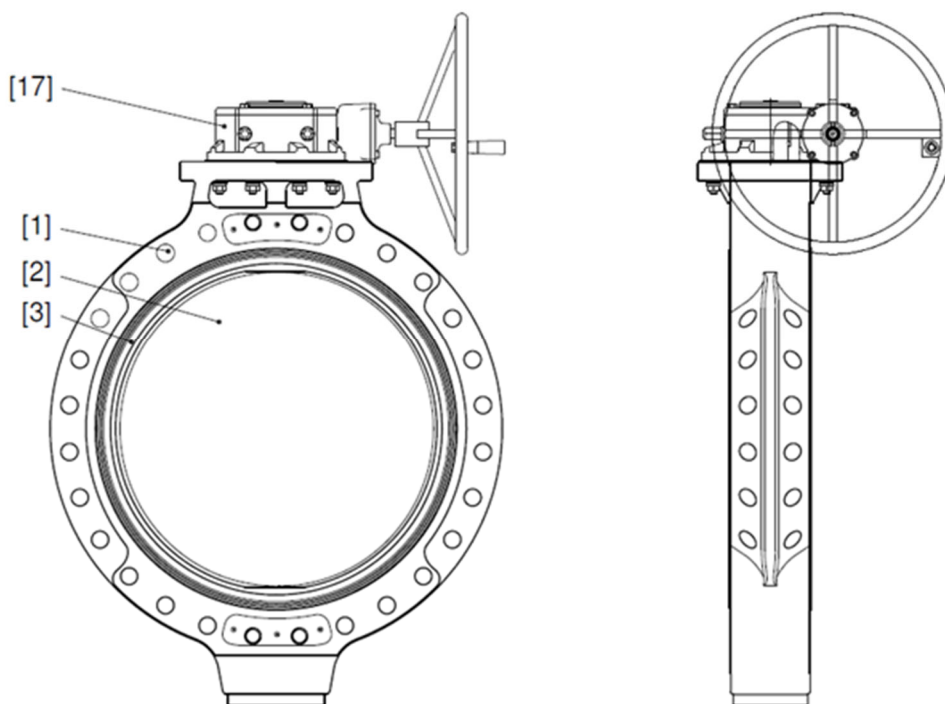

[1]	Body	[3]	Seat
[2]	Disc	[17]	Gear box



## 4. Product Specifications





### Model number table

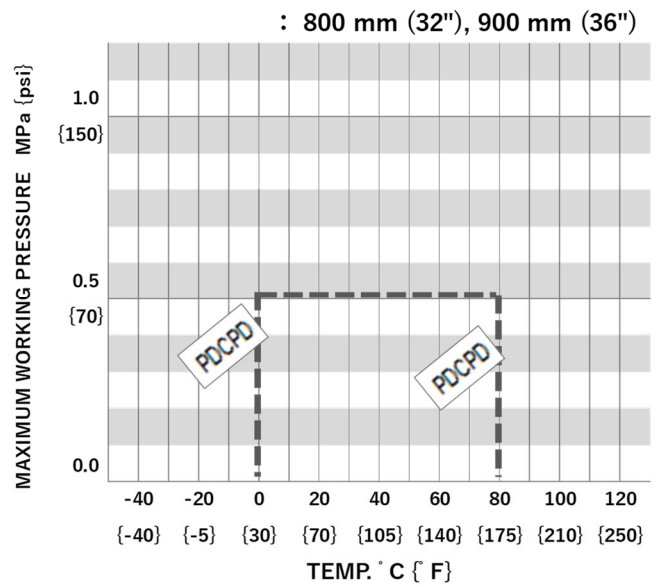
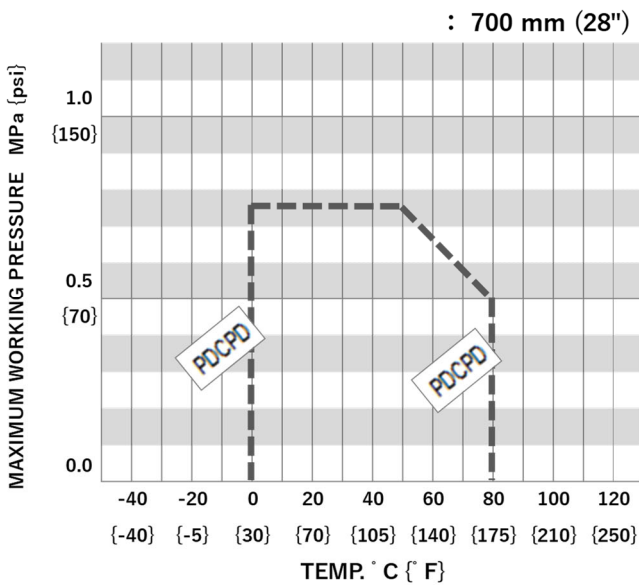

ACTUATION	TYPE	ACTUATOR TYPE	BODY MATERIAL	SEAL MATERIAL	CONNECTION	STANDARD	SIZE	DISC PVDF
V	58	SG	D	E	W	*	* * *	1M
V MANUAL VALVE	58 TYPE 58	SG SIDE GEAR TYPE	D PDCPD	E EPDM	W WAFER	1 JIS 10K D DIN A ANSI	700 700mm 800 800mm 900 900mm	Used when the disc material is PVDF.

### Relationship between maximum allowable pressure and temperature

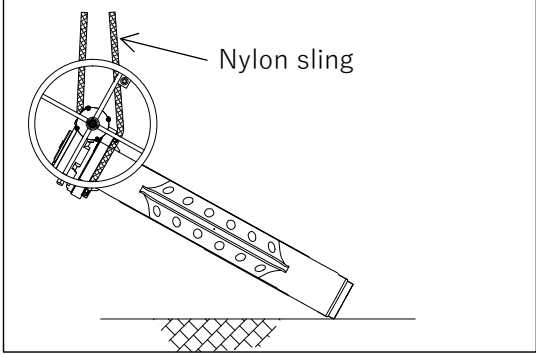

**5. Mounting method**

 <b>Warning</b>	
<p> <b>Prohibition</b></p>	<p><b>The valve can be damaged, or leak.</b></p> <ul style="list-style-type: none"> <li>▶ When lifting the valve, hang the nylon sling on the neck of the valve.</li> </ul> <div style="text-align: right; margin-right: 50px;">  </div> <p><b>Serious injury can result.</b></p> <ul style="list-style-type: none"> <li>▶ Be sure to perform safety inspections of the machine tool and power tool beforehand.</li> <li>▶ Wear appropriate protective equipment for the work details when installing piping.</li> </ul>
<p> <b>Forcing</b></p>	<p><b>Serious injury can result.</b></p> <ul style="list-style-type: none"> <li>▶ When hanging or slinging a valve, pay sufficient attention to safety, and do not enter under the load.</li> </ul>

 <b>Caution</b>	
<p> <b>Prohibition</b></p>	<p><b>The valve can be damaged, or leak.</b></p> <ul style="list-style-type: none"> <li>▶ Do not over-tighten when piping support is removed with a U-band, etc.</li> <li>▶ When installing piping, do not install it in the fully closed state. (The disc may get caught in the seat and the operating torque may become heavy, making it impossible to open and close it.)</li> <li>▶ Never carry or install the disc in the condition of "impossible" shown in Fig. 5-1, as it will scratch the sealing surface of the disc.</li> <li>▶ Do not tighten the bolt nut for piping with the specified torque or more.</li> <li>▶ When installing the product, make sure that no excessive stress such as tension, compression, bending or impact is applied to the piping or valve.</li> <li>▶ Use a connection flange with a full-face seat. If a flange other than the full face seat (flange adapter/backing flange, etc.) is unavoidably used, the flange corners may bite into the seat depending on the size of the valve, causing damage to the seat. Contact us in advance.</li> <li>▶ Check that the flange standards of each other are correct.</li> <li>▶ Fix the bolt nut for piping by tightening it from the through hole. (Tightening first from the metal fitting part of the main body may damage it.)</li> </ul>

**⚠ Caution**

**⊘ Prohibition**

**The valve can be damaged, or leak.**

- ▶ The product is in the "Good" state as shown in Fig. 5-1. Before opening or closing the valve for piping installation, be sure to return the disc to the original condition (Refer to "Good" in Fig. 5-1) after operation.
- ▶ If the inner diameter of the connection (flange/pipe) is small, chamfer the inside of the connection to avoid contact between the valve disk and the inner surface of the connection. (See Fig. 5-2.)
- ▶ The inner diameter of the connecting part should be equal to or larger than the value shown in Table 5-1.

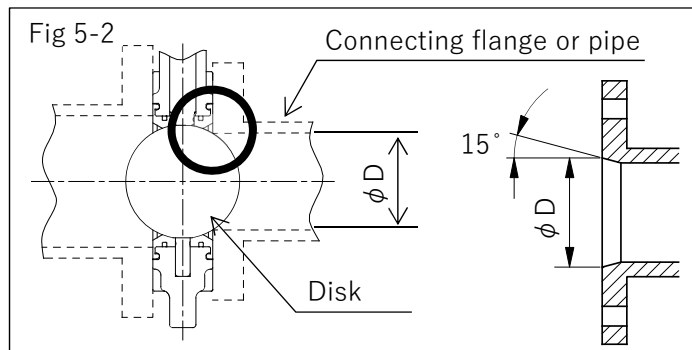
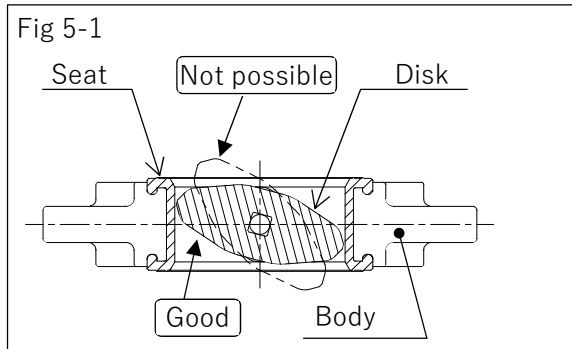

Table 5-1 Minimum bore size

SIZE (mm)	700	800	900
Bore diameter D(mm)	677	777	877

- Preparations ▶ Torque wrench ▶ wrench ▶ through bolt ▶ screw-in bolt  
 ▶ Nut/Washer ▶ Short pipe ▶ cloth

### Dimensions of Through Bolt and Screw-in Bolt

▶ The length of the bolt to be used varies depending on the connection standard and flange material.  
 Obtain the bolt length using the following formula.

- L : Length of through bolt
- S : Thread length of through bolt
- L1 : Length of screw
- D : Nominal thread
- W : Between the surfaces of valves
- a : Thread depth
- b : Flange thickness
- c : Thickness of washer
- d : Thickness of nut
- e : Bolt output (Thread pitch × 3)

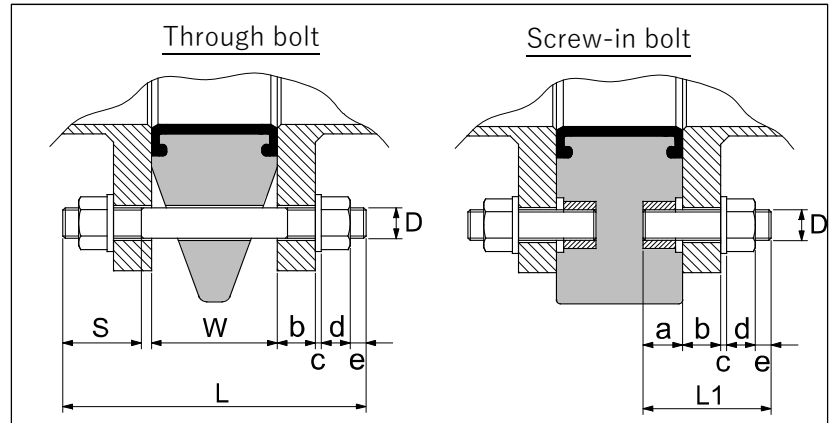

[Through bolt]  $L \geq W + (b + c + d + e) \times 2$   
 $S \geq D \times 2.5$   
 [Screw-in bolt]  $L1 \geq a + b + c + d + e$

		SIZE (mm)	700	800	900
Common	W	Between valve faces (mm)	169	198	211
JIS10K	D	Nominal thread	M30	M30	M30
	A	Thread depth (mm)	28	30	30
	Quantity	Through bolt (Book)	20	24	24
		Screw-in bolt (Book)	8	8	8
		Nut (pcs.)	48	56	56
	Washer (Sheet)	48	56	56	
DIN	D	Nominal thread	M27	M30	M30
	A	Thread depth (mm)	28	30	30
	Quantity	Through bolt (Book)	20	20	24
		Screw-in bolt (Book)	8	8	8
		Nut (pcs.)	48	48	56
	Washer (Sheet)	48	48	56	
ANSI	D	Nominal thread	UNC 1¼-7	UNC 1½-6	UNC 1½-6
	A	Thread depth (mm)	28	30	30
	Quantity	Through bolt (Book)	24	24	28
		Screw-in bolt (Book)	8	8	8
		Nut (pcs.)	56	56	64
	Washer (Sheet)	56	56	64	

**[Procedure]**

- 1) Set the short tube in advance. Place the short tube on the pedestal so that the center of the valve and the center of the short tube are almost the same when the valve is raised. Wipe up the flange surface of the short tube with a waste cloth.
- 2) Raise the valve. Wind the nylon sling around the neck of the valve to gradually raise the valve and wipe up the inner surface of the valve with a waste cloth.
- 3) Gradually lower the valve between the set short pipes.
- 4) Temporarily connect the short pipe and the valve. Move the valve or short tube little by little so that the bolt hole of the short tube and the bolt hole of the valve are approximately aligned, attach the through bolt and screw-in bolt, and tighten the nut lightly.
- 5) After installing all the bolts lightly, gradually tighten only the through bolts to the specified torque value diagonally with a torque wrench. (See Table 5-2 and Figure 5-3.)
- 6) After completing the tightening of the through bolts, gradually tighten the screw-in bolts diagonally to the specified torque value with a torque wrench. (See Table 5-2 and Figure 5-3.)
- 7) Tighten all pipe bolts clockwise to the specified torque value for at least two turns. (See Table 5-2 and Figure 5-3.)

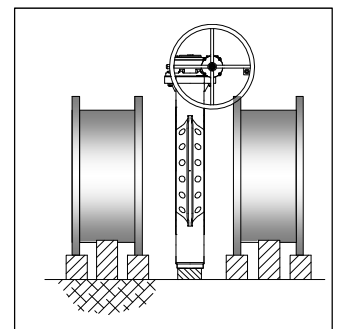
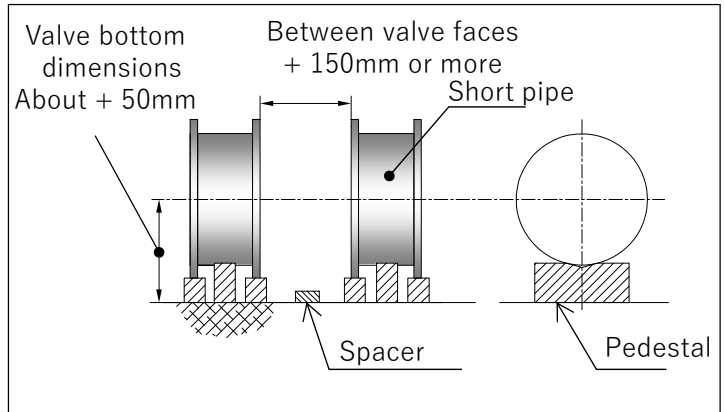
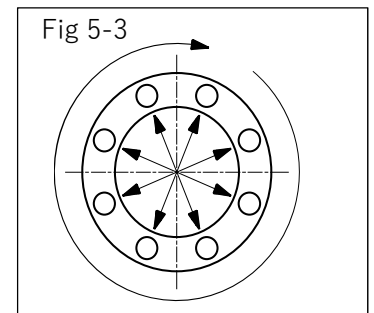

Table 5-2 Flange tightening torque

SIZE (mm)	700	800	900
Tightening torque	130	130	170
N-m {kgf-cm}	{1,330}	{1,330}	{1,740}



**6. Support installation method**

**⚠ Caution**



**Prohibition**

**The valve can be damaged or leak.**

▶ Do not cause large vibrations to the valve by the piping around the pump.

Preparations : ▶ Wrench                      ▶ U-band (with screws) ▶ rubber-sheet

**Horizontal piping**

- ▶ Place the frame under the valve.
- ▶ Lay a rubber sheet under the gearbox and support it with the frame.
- ▶ Lay a rubber sheet on the pipe and secure it with a U-band, etc.

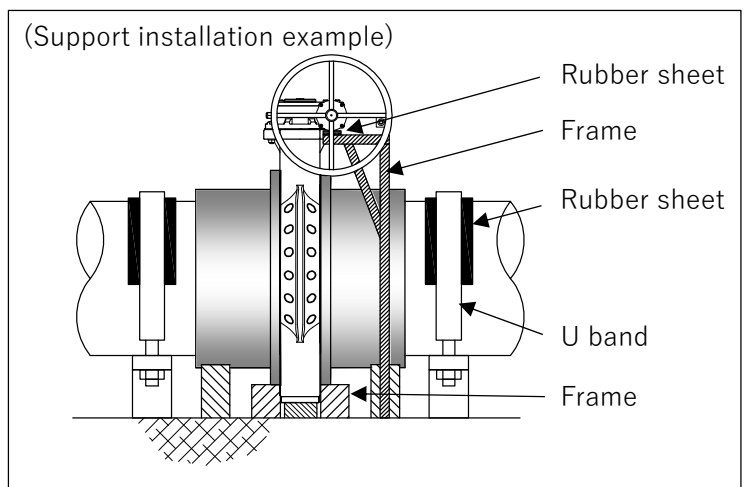

**Vertical piping**

- ▶ By placing a rubber sheet under the gearbox and placing it on a frame Support.
- ▶ Lay a rubber sheet on the pipe and secure it with a U-band, etc.

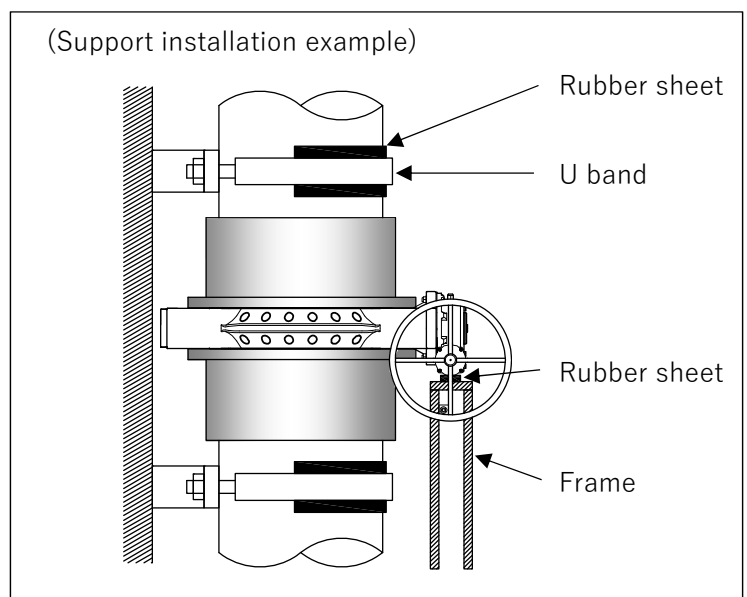

## 7. Operation method

### Caution



#### Prohibition

**The valve can be damaged, or leak.**

- ▶ Do not turn the manual handle beyond the maximum operating torque value shown in Table 7-1.
- ▶ Manual operation must be performed by hand.
- ▶ Operate the disc and seat when they are wet.  
(Otherwise, it may not work properly.)

#### [Procedure]

1) While checking the movement of the opening instruction at the top of the gear box, gently rotate the handle to open or close it.

[For left open spec.]

- ▶ Clockwise ; Valve closed
- ▶ Anticlockwise ; Valve open

[For right open spec.]

- ▶ Clockwise ; Valve open
- ▶ Anticlockwise ; Valve closed

Table 7-1 Handle revolutions

SIZE (mm)	700	800	900
Handle revolutions	55	87	87

**8. Water flow and adjusting the stopper of the gear box**

**⚠ Caution**



**Prohibition**

**The valve can be damaged or leak.**

- ▶ Do not lose the resin washer on the lock nut.
- ▶ After adjustment, securely fix the cap nut so that it does not loosen. (There is a risk of rainwater entering the gearbox.)

**9-1. Water flow**

**[Procedure]**

- 1) Before passing water, make sure that there is no foreign matter in the pipe that could damage the valve seat. Open the valve fully before passing water.

**9-2. Adjusting the stopper of the gear box**

**[Procedure]**

- ※ The degree of tightening of the valve element has been adjusted. However, if water leaks during use, adjust the operating position of the stopper bolt of the drive section.

Preparations ▶ Wrench                      ▶ Hex Wrench

**[Procedure]**

- 1) Remove the cap nut in the direction you want to adjust (fully open or fully closed) by turning it counterclockwise with a spanner.
- 2) Remove the resin washer attached to the stopper bolt.
- 3) Turn the stopper bolt counterclockwise with an Allen wrench to the extent that it does not come off. (Approx. 2 rotations)
- 4) Operate the valve in the direction you want to adjust (fully open or fully closed) by manual operation.
- 5) Turn the stopper bolt in the direction you want to adjust clockwise until you cannot turn it with an **Allen** wrench.
- 6) Attach the resin washer to the stopper bolt.
- 7) Screw the glove nut clockwise onto the stopper bolt with the glove.
- 8) Screw the clasp nut clockwise with a wrench to the extent that the plastic washer does not break. (Approx. 1/4 turn)
- 9) Perform manual operation to check that the stopper is functioning at the proper position.

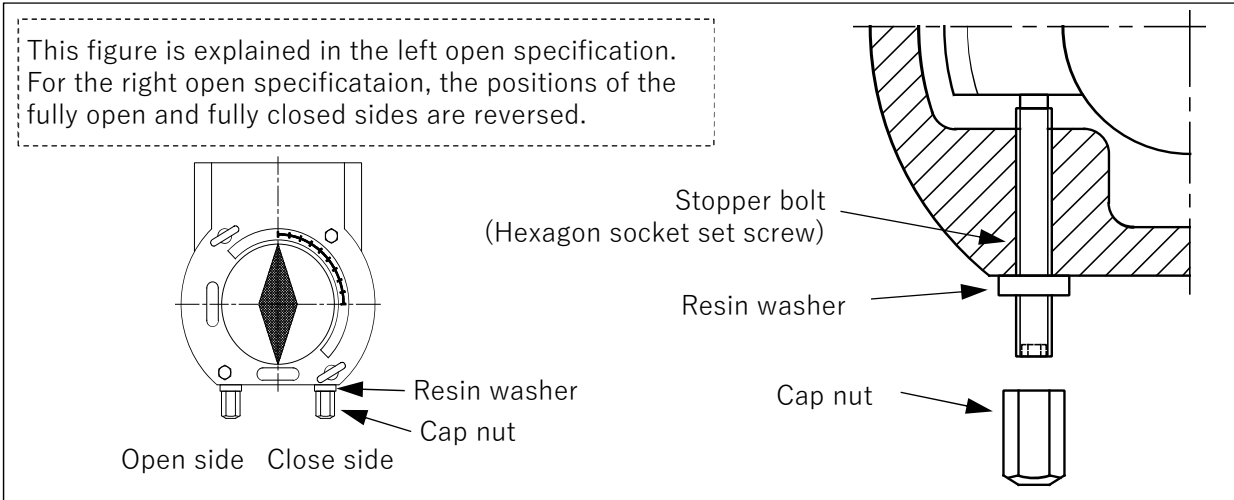



**9. Inspection item**

 **Caution**

 <b>Forcing</b>	<p><b>The valve can be damaged, or leak.</b></p> <ul style="list-style-type: none"> <li>▶ Maintenance should be performed every 3 to 6 months as a guide in order to keep the watch in normal condition and use it for a long time. Pay particular attention to temperature changes and aging during long-term storage or shutdown or use.</li> <li>▶ When removing the valve from the piping when replacing the valve or parts, completely remove the fluid from the piping before starting work.</li> <li>▶ If any trouble is found, take the appropriate action referring to "10. Troubleshooting."</li> </ul>
--	---

**Daily inspection**

Inspection items and inspection methods	Guideline of judgment	Check point	Treatment method
External leakage (visual inspection)	No leakage	Pipe flange connection	① Retighten the pipe bolts to the specified torque. ② Remove the valve from the pipe and retighten the pipe bolts. (Ref: 5. Mounting method)
		• Top flange of valve (joint between valve body and gearbox) • Bottom flange of the valve	Remove the valve from the pipe and replace the valve. (Ref: 5. Mounting method)
		Surface of the entire valve	Remove the valve from the pipe and replace the valve. (Ref: 5. Mounting method)
Internal leakage (visual and measurement)	No leakage	Leakage to secondary side when valve is fully closed	Remove the valve from the pipe and replace the valve. (Ref: 5. Mounting method)
		Measured values of flowmeters, pressure gauges, etc.	Remove the valve from the pipe and replace the valve. (Ref: 5. Mounting method)
Abnormal noise (hearing)	No abnormal noise	Valve	Remove the valve from the pipe and replace the valve. (Ref: 5. Piping method)
		Piping around the valve	Reconfirm the conditions of use (Ref: 2. Safety Precautions [Handling the Product])

## Periodic inspection

### ●Guideline for the inspection cycle: 3 months

Inspection items and inspection methods	Guideline of judgment	Check point	Remedy for malfunctions
Vibration (palpation)	No difference from other parts	Valve	Recheck the operating conditions and remove the source of vibration. (Ref: 2. Safety Precautions [Handling the Product])
		Piping around the valve	Recheck the operating conditions and remove the source of vibration. (Ref: 2. Safety Precautions [Handling the Product])

### ●Guideline of the inspection cycle: 6 months

Inspection items and inspection methods	Guideline of judgment	Check point	Remedy for malfunctions
Operability of manual handle (touch)	Rotates smoothly	Manual operation unit	Remove the valve from the pipe and replace the valve. (Ref: 5. Piping method)
Looseness of bolts (visual and palpation)	No Loose	Body top flange	Retighten the mounting bolts
		Flange piping	Retighten the pipe bolts to the specified torque. (Ref: 5. Piping method)
Corrosion Or rust (visual inspection)	No corrosion or rust	Appearance of the product	Remove the valve from the pipe and replace the valve. (Ref: 5. Piping method)
Product damage	No scratches, cracks, or deformation	Appearance of the product	Remove the valve from the pipe and replace the valve. (Ref: 5. Piping method)

**10. Cause of malfunction and remedy**

 **Caution**

 **Forcing**

**There is a danger of injury.**

- ▶ If any malfunction is found, immediately stop using the product and take appropriate action.
- ▶ When removing the valve from the piping when replacing the valve or parts, completely remove the fluid from the piping before starting work.

Failure phenomenon	Possible cause	Measures and measures
Handle does not turn (cannot turn)	The valve is already fully open (or fully closed).	Rotate the handle in the opposite direction (Ref: 7. Operation)
	Foreign matter caught in valve	Remove the valve from the piping, disassemble it, and remove foreign matter. (Ref: 5. Piping method)
	Piping stress is applied to the valve.	Remove the piping stress
	The torque of the valve has increased due to the effects of the fluid (temperature, components, pressure, etc.)	Reconfirm the conditions of use (Ref: 2. Safety Precautions [Handling the Product])
Internal leakage from sheet	High fluid pressure	[4. Check the specifications of the product [Relationship between the maximum allowable pressure and temperature], and use the product below the maximum allowable pressure.
	Damage to the disc or seat due to foreign matter biting	Remove the valve from the piping and check for foreign matter and damage to the disc and seat. If the disc or seat is damaged, replace and reinstall the valve. (Contact your nearest dealer or our sales office.)
	Excessive tightening of pipe bolts	Lower the pressure of the fluid, loosen the pipe bolts, and re-tighten them diagonally (Ref: 5. Mounting method)
	Disk or seat worn or damaged	Remove the valve from the piping and check the disc and seat for wear or damage. If the disc or seat is worn or damaged, replace and reinstall the valve. (Contact your nearest dealer or our sales office.)
	Disk fully closed position shift	Check the fully closed position with the opening indicator hand of the gearbox. Adjust the position of the stopper on the fully closed side of the gearbox if there is a gap. (Ref.: 8. How to adjust water flow and stopper of gear box)
	Looseness or uneven tightening of pipe bolts	By reducing the pressure of the fluid and re-tightening the pipe bolts diagonally (Ref: 5. Mounting method)
	Sheet wear or damage due to long-term use and frequent opening and closing	Remove the valve from the piping and check the seat for wear or damage. If the seat is worn or damaged, replace and reinstall the valve. (Contact your nearest dealer or our sales office.)

**CAUSE OF FAILURE AND HOW TO REMEDY (continued)**

Failure phenomenon	Possible cause	Measures and measures
Leakage from flange connections	Looseness or uneven tightening of pipe bolts	By reducing the fluid pressure and re-tightening the pipe bolts diagonally (Ref: 5. Mounting method)
	Sheet blind or damaged	Remove the valve from the piping and check the seat for kinks and scratches. If there is a problem, replace the valve and reinstall it. (Contact your nearest dealer or our sales office.)
	Foreign matter caught between flange and seat	Remove the valve from the piping and check for foreign matter. If there is any foreign matter, remove it, clean it, and reinstall the valve. If the seat is damaged, replace and reinstall the valve. (Contact your nearest dealer or our sales office.)
	Misalignment between flange and valve shaft	Loosen the pipe bolts, align the shaft and reinstall. (Ref: 5. Mounting method)
Leakage from the top flange of the valve or from the bottom of the valve	Wear or damage to stem seal	Remove valve from piping, replace valve and reinstall (Contact your nearest dealer or our sales office.)

**11. Treatment method for residual materials and waste materials**

 <b>Warning</b>	
 <b>Forcing</b>	<p><b>When burnt, toxic gas is generated.</b></p> <p>▶ When disposing of the product or parts, please dispose of them according to the guidelines of each local authority by a professional disposal company.</p>

**Inquiries**

Contact the nearest dealer, our sales office, or our web website for inquiries about this product.

**[User's manual]**

Butterfly valve type 58

Side gear type

700~900mm



<https://www.asahi-yukizai.co.jp/en>

Please note that the content of this manual is subject to change without notice.

**March 2024**