

SOCKET END

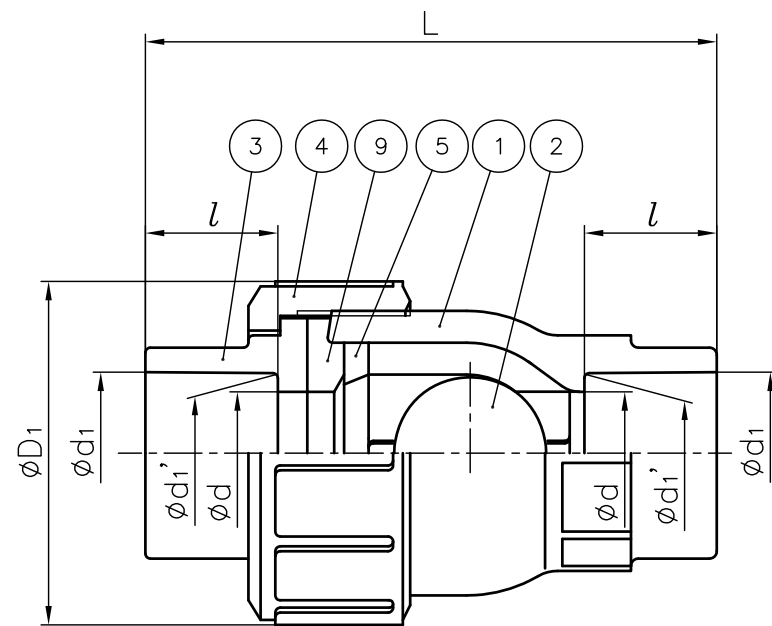

THREADED END

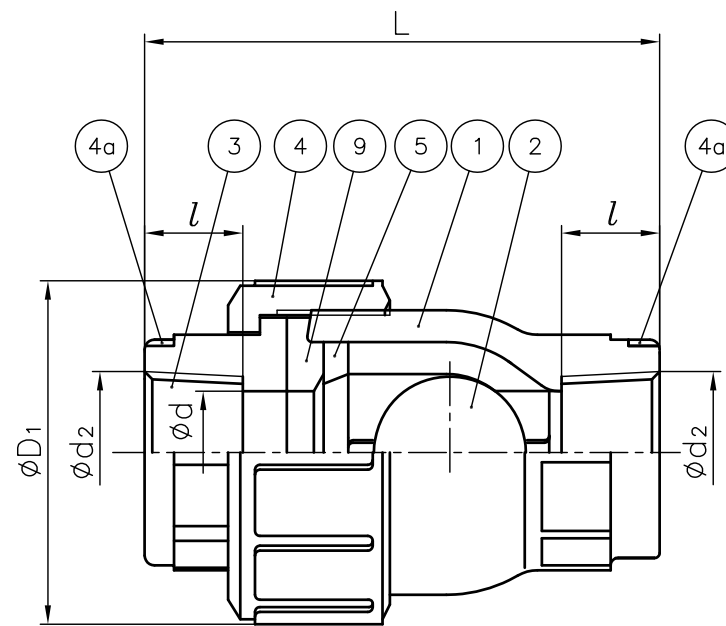

DIMENSIONS TABLE

UNIT: mm

NOMINAL SIZE	d	D <sub>1</sub>	SOCKET END				THREADED END						
			PVC,C-PVC		PP,PVDF		d <sub>2</sub>	l	L				
			d <sub>1</sub>	l	L	d <sub>1</sub>			d <sub>1</sub> '	l	L	PVC C-PVC	PP PVDF
15mm 1/2"	15	48	20	16	81	19.50	19.30	14	78	Rp 1/2	15	80	78
20 3/4"	20	60	25	19	96	24.50	24.30	16	90	Rp 3/4	17	95	92
25 1"	25	70	32	22	107	31.50	31.30	18	99	Rp 1	20	105	102
40 1 1/2"	40	96	50	31	150	49.45	49.20	23	135	Rp 1 1/2	25	141	137
50 2"	51	106	63	38	181	62.50	62.10	27	160	Rp 2	28	164	160
80 3"	78	152	90	51	248	89.20	88.85	35	217	Rp 3	35	222	216
100 4"	100	210	110	61	330	109.05	108.65	41	291	Rp 4	45	308	301

NOTE. The shape and appearance of assembly differ a little with nominal size compared to this drawing.

4a	RING <sup>1)</sup>	2	STAINLESS STEEL (SUS304)	1) C-PVC Body, Threaded End : Used for 15~25mm  2) Used for Flanged End
9	SEAT	1	<input type="checkbox"/> EPDM <input type="checkbox"/> FKM <input type="checkbox"/> Other ( )	
8	STOP RING (B) <sup>2)</sup>	1	PVDF	
7	PIPE <sup>2)</sup>	1	<input type="checkbox"/> PVC <input type="checkbox"/> C-PVC <input type="checkbox"/> PP <input type="checkbox"/> PVDF	
6	TS FLANGE <sup>2)</sup>	1		
5	STOP RING (A)	1		
4	UNION NUT	1		
3	END CONNECTOR	1		
2	BALL	1		
1	BODY	1		
No.	DESCRIPTION	QTY.	MATERIAL	REMARKS
ITEM	BALL CHECK VALVE ASS'Y DIN : <input type="checkbox"/> SOCKET END, <input type="checkbox"/> THREADED END 15mm (1/2") ~ 100mm (4")			
DRAWN	M.Oosako	DATE	SCALE	
CHECKED	H.Kawano	DEC.20.2011		
APPROVED	Y.Ozaki	DRAWING No.		
		BC-60001DE		4
SPECIAL ORDER No.	ASAHI YUKIZAI CORPORATION			