

DIMENSIONS TABLE

Unit : mm

Nominal Size		d	DIN PN10				L	t	D <sub>1</sub>	H	H <sub>1</sub>	A	A'	A <sub>1</sub>	A <sub>2</sub>	A <sub>3</sub>	P
			D	C	n	h											
15mm	1/2"	16	95	65	4	14	160	12	102	337	51	215	286	130	144	70	1/4
25	1	25	115	85	4	14	184	14	116	368	63	215	286	130	144	70	1/4

NOTE. 1. Operating Pressure : 0.4MPa G  
 2. The shape and appearance of assembly differ a little with nominal size compared to this drawing.

LIFT (L) TABLE

Unit : mm

Size	Quality	Port Size $\phi Q$					
		6	8	10	15	20	25
15mm	EQ%	17	16	17	18	/	/
	Linear	16	16	15	16	/	/
25mm	EQ%	16.5	16	16	16	22	24
	Linear	16	16	14	15	19.5	25

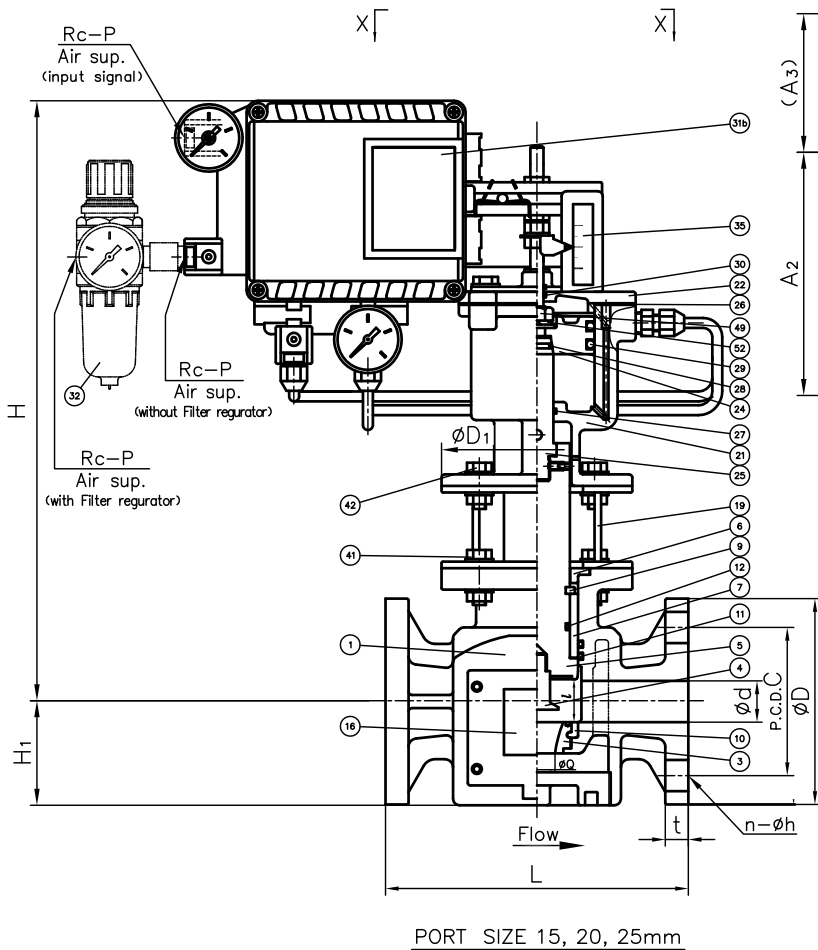

PORT SIZE 15, 20, 25mm

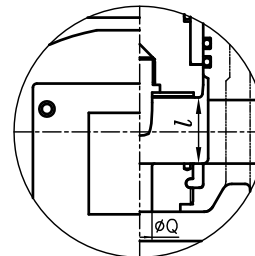
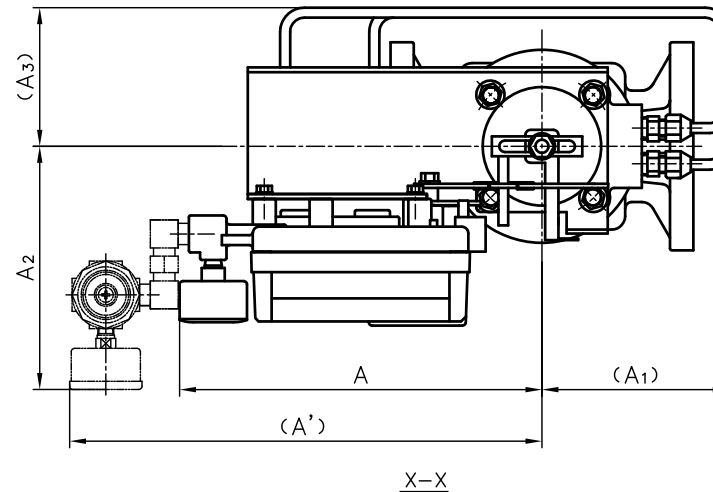

PORT SIZE 6, 8, 10mm

52	SPRING WASHER	1	SPRING STEEL	SUP
49	NUT (A)	1	STAINLESS STEEL	SUS304
42	BOLT · NUT (B)	4-sets	STAINLESS STEEL	SUS304
41	BOLT · NUT (A)	4-sets	STAINLESS STEEL	SUS304
35	INDICATOR SEAL	1	ACRYL	
32	FILTER REGULATOR	-	ZINC ALLOYS DIE CASTINGS (ZDC2) etc.	□ARU2-02-8A-G □nothing
31b	P-P POSITIONER	1	ALUMINUM ALLOYS DIE CASTINGS (ADC12) etc.	YT-1200L
30	O-RING (H)	2	NBR	
29	O-RING (G)	2	NBR	
28	O-RING (F)	1	NBR	
27	O-RING (E)	1	NBR	
26	PACKING (A)	1	NBR	
25	STEM	1	STAINLESS STEEL	SUS304
24	PISTON (B)	1	CAST ALUMINUM ALLOY (AC5A)	
22	CYLINDER COVER	1	CAST ALUMINUM ALLOY (AC4C)	epoxy coat.
21	CYLINDER	1	CAST ALUMINUM ALLOY (AC4C)	epoxy coat.
19	STAND	1	STAINLESS STEEL	SUS304
16	NAME PLATE	2	ALUMINIUM	
12	O-RING (B)	1	□EPDM □Viflon-F	
11	O-RING (A)	2	□Viflon-C □others	
10	SEAT	1	( )	
9	STOP RING	1	PVDF	
7	BUSH	1	PTFE	
6	PISTON HOLDER	1	PVC	
5	PISTON (A)	1	PVC	
4	PLUG	1	PVC	
3	ORIFICE TUBE	1	PVC	
1	BODY	1	PVC	
No.	DESCRIPTION	QTY.	MATERIAL	REMARKS

ITEM	CONTROL VALVE PNEUMATIC ACTUATED MODEL TYPE AV ASSY DOUBLE ACTING DIN PN10 : 15mm (1/2") · 25mm (1") with P-P POSITIONER, FILTER REGULATOR		
DRAWN	M.Iwakiri	DATE	SCALE
CHECKED	H.Kawano	AUG.20.2019	~
APPROVED	K.Koushou	DRAWING No.	
SPECIAL ORDER No.	CV-AA026DE		△
<b>ASAHI YUKIZAI CORPORATION</b>			