

DIMENSIONS TABLE

UNIT: inch

NOMINAL SIZE	d	ANSI Class 150				D ₂	D ₃	L		t	l (LIFT)	H	H ₁	A ₃	S	S ₁	S ₂	P	
		D	C	n	h			GRINNELL STANDARD	AV STANDARD										
1/2	15mm	0.63	3.50	2.38	4	0.62	2.13x2.60	5.12	4.25	4.33	0.43	0.39	7.32	0.77	2.68	0.98	0.28	0.51	1/4
3/4	20	0.79	3.88	2.75	4	0.62	2.13x2.60	5.12	5.88	4.72	0.51	0.39	7.40	0.69	2.68	0.98	0.28	0.51	1/4
1	25	0.98	4.25	3.12	4	0.62	2.64x3.15	5.12	5.88	5.12	0.59	0.47	7.60	0.73	2.68	0.98	0.28	0.51	1/4
1 1/4	32	1.26	4.62	3.50	4	0.62	2.64x3.15	5.12	6.38	-	0.63	0.47	7.76	0.89	2.68	0.98	0.28	0.51	1/4
1 1/2	40	1.57	5.00	3.88	4	0.62	4.25x4.25	6.85	6.94	7.09	0.63	0.83	11.54	1.08	3.62	1.77	0.35	0.59	1/4
2	50	2.05	6.00	4.75	4	0.75	4.84x4.84	6.85	7.94	8.27	0.79	0.98	11.89	1.42	3.62	1.77	0.35	0.59	1/4

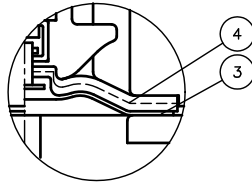
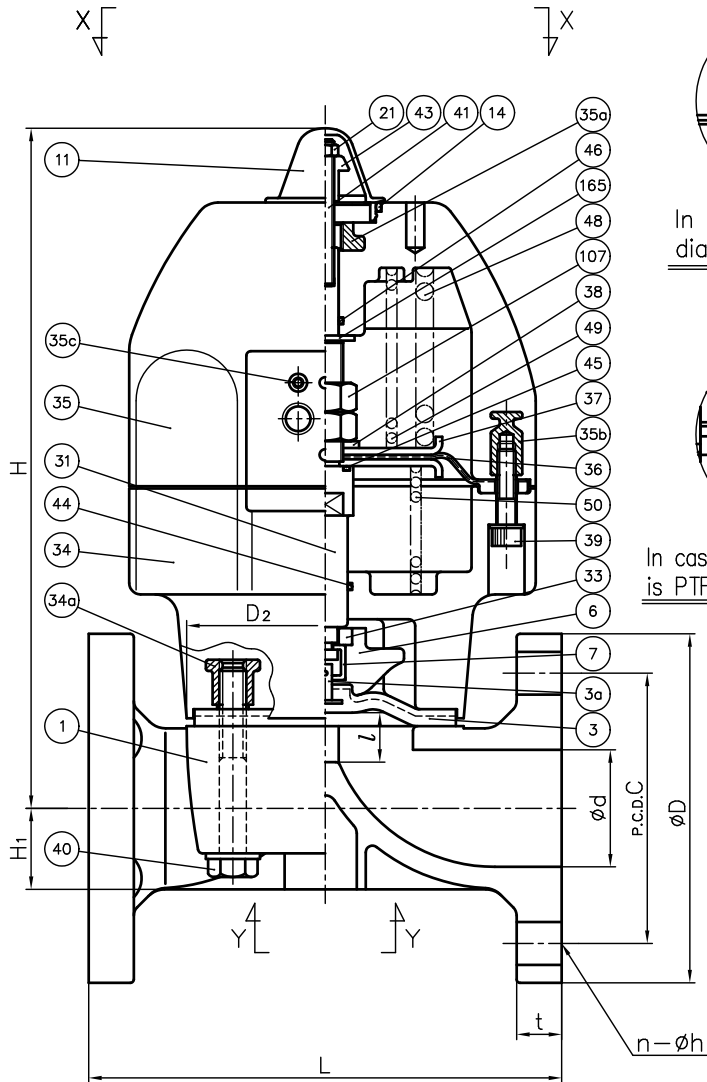

In case material of diaphragm is PTFE.

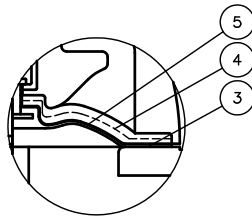

In case material of diaphragm is PTFE with cushion cover.

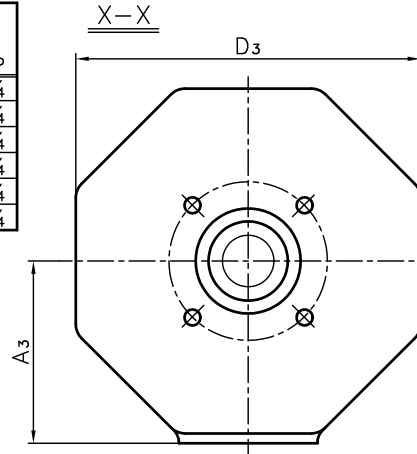
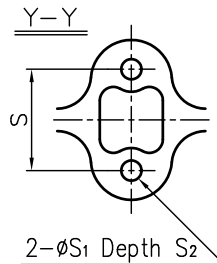

Face of Air Supply (Double Acting)

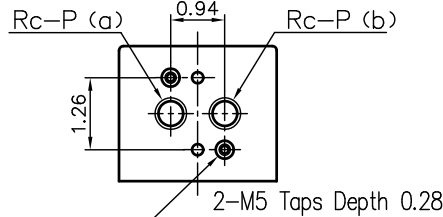

Face of Air Supply (Air to Open)

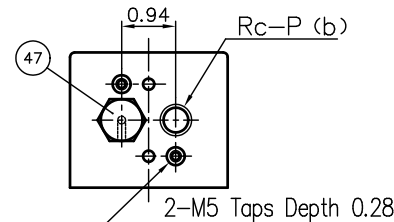

Face of Air Supply (Air to Shut)

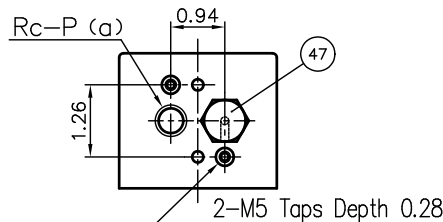

NOTE.

- Operation of permission pressure: 0.4~0.6MPa G
Air to open : 1"~2" : 0.45~0.6MPa G
(only fluid pressure is 0)
- Double Acting : Valve open : Port (a) Exhaust
Port (b) Supply
Valve shut : Port (a) Supply
Port (b) Exhaust
Air To Open : Valve open : Port (b) Supply
Valve shut : Port (b) Exhaust
Air To Shut : Valve open : Port (a) Exhaust
Valve shut : Port (a) Supply
- Diaphragms except EPDM and PTFE are available in FKM, VIFLON-C (FKM-C), VIFLON-F (FKM-F), CSM and NBR when required.
- The shape and appearance of assembly differ a little with nominal size compared to this drawing.

165	WASHER (A)	1	STAINLESS STEEL	SUS304
107	LOCK NUT	2	STAINLESS STEEL	SUS304
50	SPRING (C)	1	SPRING STEEL (SWO5M-B)	Used for Air to Shut
49	SPRING (B)	1	SPRING STEEL (SWO5M-B)	Used for Air to Open
48	SPRING (A)	1	SPRING STEEL (SWO5M-B)	Used for Air to Open
47	NIPPLE	1	COPPER ALLOY (C3604)	Used for Air to Shut and Air to Open
46	O-RING (F)	1	NBR	
45	O-RING (E)	1	NBR	
44	O-RING (D)	1	NBR	
43	STOPPER	1	STAINLESS STEEL	SUS304
41	INDICATING ROD	1	STAINLESS STEEL	SUS304
40	BOLT (B)	4	STAINLESS STEEL	SUS304
39	BOLT (A)	8	STAINLESS STEEL	SUS304
38	CONICAL SPRING WASHER (B)	1	STAINLESS STEEL	SUS304
37	CYLINDER DIAPHRAGM PLATE	2	STAINLESS STEEL	SUS304
36	CYLINDER DIAPHRAGM	1	NBR	
35c	SCREWED METAL OF CYLINDER BONNET	2	STAINLESS STEEL	SUS303
35b	INSERTED METAL OF CYLINDER BONNET (B)	8	COPPER ALLOY	C3604
35a	INSERTED METAL OF CYLINDER BONNET (A)	1	STAINLESS STEEL	SUS304
35	CYLINDER BONNET	1	PPG	
34a	INSERTED METAL OF CYLINDER BODY	1	COPPER ALLOY	C3604
34	CYLINDER BODY	1	PPG	
33	COMPRESSOR PUSHING PLATE	1	COPPER ALLOY	C3604
31	STEM (A)	1	COPPER ALLOY	C3604
21	NUT	1	STAINLESS STEEL	SUS304
14	O-RING (A)	1	EPDM	
11	GAUGE COVER	1	PC	
7	JOINT	1	STAINLESS STEEL	SUS304
6	COMPRESSOR	1	PVDF	
5	CUSHION COVER	1	<input type="checkbox"/> Nothing <input type="checkbox"/> PVDF	Used for PTFE Diaphragm
4	CUSHION	1	EPDM	Used for PTFE Diaphragm
3a	INSERTED METAL OF DIAPHRAGM	1	STAINLESS STEEL	SUS304
3	DIAPHRAGM	1	<input type="checkbox"/> EPDM <input type="checkbox"/> PTFE <input type="checkbox"/> others	()
1	BODY	1	<input type="checkbox"/> PVC <input type="checkbox"/> C-PVC <input type="checkbox"/> PP <input type="checkbox"/> PVDF	

No.	DESCRIPTION	QTY.	MATERIAL	REMARKS
ITEM	DIAPHRAGM VALVE (TYPE14) PNEUMATIC ACTUATED MODEL TYPE AN ASSY □DOUBLE ACTING, □AIR TO OPEN, □AIR TO SHUT ANSI Class 150 : FLANGED END 1/2" (15mm) ~ 2" (50mm) □GRINNELL STANDARD, □AV STANDARD			
DRAWN	M.Iwakiri	DATE	SCALE	
CHECKED	H.Kawano	FEB.7.2019	DRAWING No.	
APPROVED	K.Kaushou	D1-AA016AE	9	
SPECIAL ORDER No.	ASAHI YUKIZAI CORPORATION			