

DIMENSIONS TABLE

UNIT : inch

NOMINAL SIZE	d	ANSI Class 150				L	t		D ₁	D ₂	l	H	H ₁	S	S ₁	S ₂	S ₃	S ₄	S ₅	P
		D	C	n	h		PVC	PP PVDF												
5" 125mm	4.92	10.00	8.50	8	0.88	16.14	0.87	0.94	12.60	17.91	2.36	27.17	5.63	0.59	12.20	13.78	11.02	12.60	0.91	¼
6 150	5.83	11.00	9.50	8	0.88	18.90	0.94	1.06	15.16	20.47	2.76	31.10	5.83	0.63	14.17	15.75	12.20	13.78	0.91	¼

NOTE.

- Operation of permission pressure: 0.4~0.6MPa G
- ③ Diaphragms except EPDM and PTFE are available in FKM, VIFLON-C (FKM-C), VIFLON-F (FKM-F), CSM and NBR when required.
- The shape and appearance of assembly differ a little with nominal size compared to this drawing.

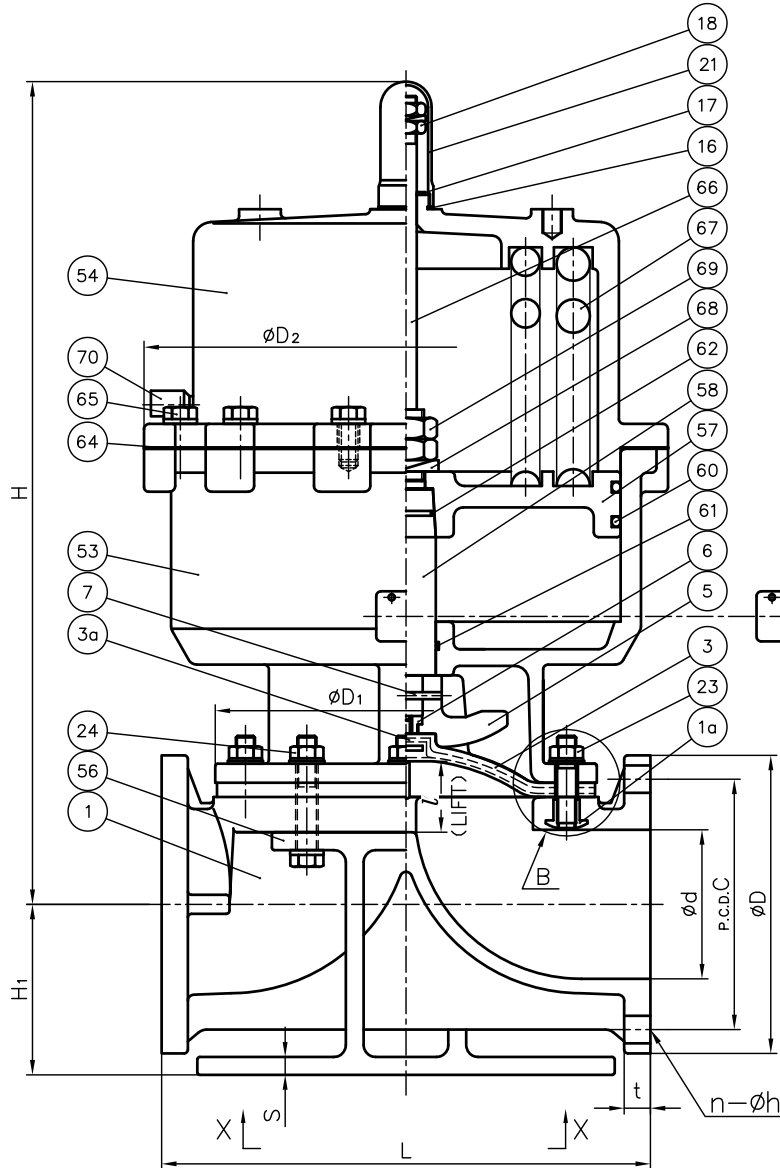

In case of PVDF body

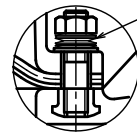

"B" Part

Rc-P AIR SUP.

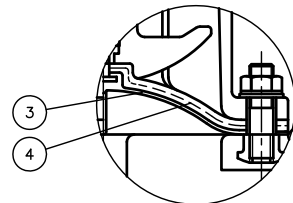

PTFE diaphragm.

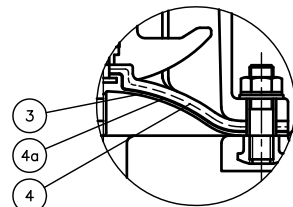

PTFE diaphragm with cushion cover.

X-X

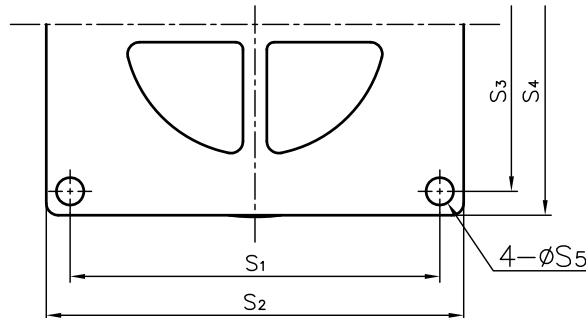

1a	INSERTED NUT	4	COPPER ALLOY (C3604)	Used for PVC & PP Body
			STAINLESS STEEL (SUS304)	Used for PVDF Body
70	CHECK VALVE FOR EXHAUST	1	COPPER ALLOY (C3604)	
69	LOCK NUT (B)	2	STAINLESS STEEL (SS400)	
68	SPRING WASHER	1	SPRING STEEL (SUP)	
67	SPRING	1	SPRING STEEL (SUP)	
66	INDICATOR ROD	1	STAINLESS STEEL (SUS304)	
65	BOLT (A)	-	STAINLESS STEEL (SUS304)	
64	SHEET GASKET (C)	1	NBR	
62	O-RING (F)	1	NBR	
61	O-RING (E)	1	NBR	
60	O-RING (D)	2	NBR	
58	STEM (A)	1	COPPER ALLOY (C3604)	
57	PISTON	1	CAST ALUMINUM ALLOY (AC5A)	
56	STAND (A)	1	CAST ALUMINUM ALLOY (AC6C)	epoxy coat.
54	CYLINDER BONNET	1	CAST ALUMINUM ALLOY (AC6C)	epoxy coat.
53	CYLINDER BODY	1	CAST ALUMINUM ALLOY (AC6C)	epoxy coat.
29	CONICAL SPRING WASHER	-	STAINLESS STEEL (SUS304)	Used for PVDF Body
24	BOLT · NUT (A)	-	STAINLESS STEEL (SUS304)	
23	STUD BOLT · NUT	4 Sets	STAINLESS STEEL (SUS304)	
21	GAUGE COVER	1	PC	
18	STOPPER	1	STAINLESS STEEL (SUS304)	
17	SHEET RING	1	STAINLESS STEEL (SUS304)	
16	SHEET GASKET (A)	1	EPDM	
7	COMPRESSOR PIN	1	STAINLESS STEEL (SUS304)	
6	COMPRESSOR NUT	1	COPPER ALLOY (C3604)	
5	COMPRESSOR	1	PVDF	
4a	CUSHION COVER	1	□Nothing □PVDF	Used for PTFE Diaphragm
4	CUSHION	1	□EPDM □Others ()	Used for PTFE Diaphragm
3a	INSERTED METAL OF DIAPHRAGM (A)	1	STAINLESS STEEL (SUS304)	
3	DIAPHRAGM	1	□EPDM □PTFE □Others ()	
1	BODY	1	□PVC □PP □PVDF	

No.	DESCRIPTION	QTY.	MATERIAL	REMARKS
ITEM	DIAPHRAGM VALVE (TYPE 15) PNEUMATIC ACTUATED MODEL TYPE AV ASS'Y AIR TO OPEN ANSI Class 150 : FLANGED END 5" (125mm) , 6" (150mm)			
DRAWN	E.Emmei	DATE	SCALE	
CHECKED	H.Kawano	MAY.23.2019		
APPROVED	K.Koushou	DRAWING No.		
		D5-AA003AE		△
SPECIAL ORDER No.	ASAHI YUKIZAI CORPORATION			