

DIMENSIONS TABLE

Unit: mm

Nominal Size	d	ANSI Class 150					L	t		D1	D2	A	l	H	H1	S	S1	S2	S3	S4	S5	P
		D	C	n	h	PVC		PP														
		PVDF																				
200mm	8"	196	343	298.5	8	22	570	28	32	430	385	195	95	742	179	20	390	440	330	380	23	3/8
250	10	247	406	362	12	25	680	30	37	540	520	260	128	890	215	23	470	540	390	460	25	3/8

NOTE.

1. Operation of permission pressure: 0.4~0.6MPa G
Valve open : Port (a) Supply, Port (b) Exhaust
Valve shut : Port (a) Exhaust, Port (b) Supply
2. Diaphragms except EPDM and PTFE are available in FKM, VIFLON-C (FKM-C), VIFLON-F (FKM-F), CSM and NBR when required.
3. The shape and appearance of assembly differ a little with nominal size compared to this drawing.

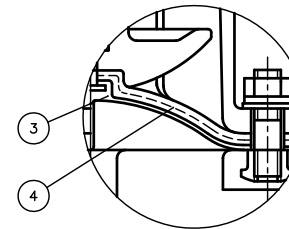
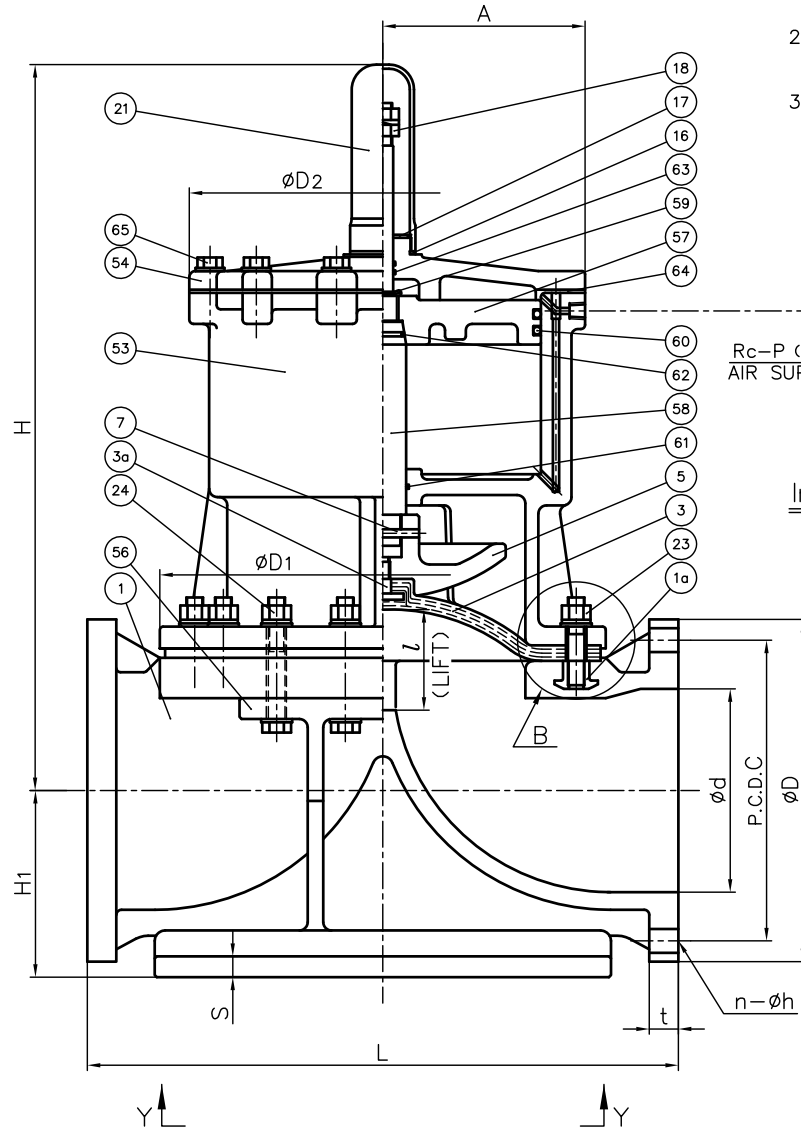

In Case of PVDF Body

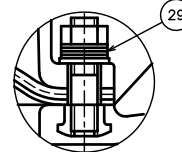

"B" Part

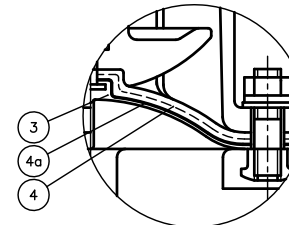

In case material of diaphragm is PTFE with cushion cover

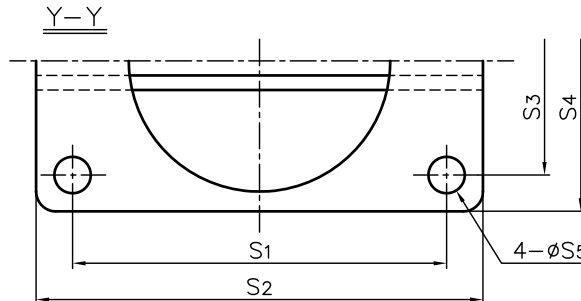

1a	INSERTED NUT	—	STAINLESS STEEL (SUS304) COPPER ALLOY (C3604)	Used for PVDF Body Used for PVC, PP Body
65	BOLT (A)	—	STAINLESS STEEL (SUS304)	
64	SHEET GASKET (C)	1	NBR	
63	O-RING (G)	2	NBR	
62	O-RING (F)	1	NBR	
61	O-RING (E)	1	NBR	
60	O-RING (D)	2	NBR	
59	STEM PIN	1	SPRING STEEL (SUP)	
58	STEM (A)	1	STAINLESS STEEL (SUS304)	
57	PISTON	1	CAST ALUMINIUM ALLOY (AC5A)	
56	STAND (A)	1	CAST ALUMINIUM ALLOY (AC4C)	Epoxy Coat
54	CYLINDER BONNET	1	CAST ALUMINIUM ALLOY (AC4C)	Epoxy Coat
53	CYLINDER BODY	1	CAST ALUMINIUM ALLOY (AC4C)	Epoxy Coat
29	CONICAL SPRING WASHER	—	STAINLESS STEEL (SUS304)	Used for PVDF Body
24	BOLT · NUT (A)	8 Sets	STAINLESS STEEL (SUS304)	
23	STUD BOLT · NUT	—	STAINLESS STEEL (SUS304)	
21	GAUGE COVER	1	PC	
18	STOPPER	1	STAINLESS STEEL (SUS304)	
17	SHEET RING	1	STAINLESS STEEL (SUS304)	
16	SHEET GASKET (A)	1	EPDM	
7	COMPRESSOR PIN	1	STAINLESS STEEL (SUS304)	
5	COMPRESSOR	1	Chromized CAST IRON (FC200)	
4a	CUSHION COVER	1	Nothing □PVDF	Used for PTFE Diaphragm
4	CUSHION	1	EPDM	
3a	INSERTED METAL OF DIAPHRAGM (A)	1	STAINLESS STEEL (SUS304)	
3	DIAPHRAGM	1	□EPDM □PTFE □Others ()	
1	BODY	1	□PVC □PP □PVDF	

No.	DESCRIPTION	QTY.	MATERIAL	REMARKS
ITEM	DIAPHRAGM VALVE (TYPE 72) PNEUMATIC ACTUATED MODEL TYPE AV ASS'Y DOUBLE ACTING ANSI Class 150 : FLANGED END 200mm (8"), 250mm (10")			
DRAWN	E.Emmei	DATE	SCALE	
CHECKED	H.Kawano	MAY.23.2019		~
APPROVED	K.Koushou	DRAWING No.		
		DF-AA005AE _m		△
SPECIAL ORDER No.	ASAHI YUKIZAI CORPORATION			