

# 3-way ball valve Type 23

## Electric Type Z

### 15~50mm(1/2"-2")

## User's Manual



Thank you for choosing our product.  
This instruction manual contains important information regarding the safe use of our product.  
Be sure to read it before handling the product.  
After reading this manual, please keep it in a place where users can refer to it at any time.

## ASAHI YUKIZAI CORPORATION

## -To use the product properly -



This instruction manual is written on the assumption that the person who handles our products has a basic knowledge of our products, electrical equipment, machinery, control, etc., and it contains technical terms depending on the handling contents.

Please read this manual carefully and fully understand the contents and observe the safety precautions for proper use.



In this manual, the warning, caution, prohibition, and enforcement are categorized together with the symbol to inform the situation and scale of human injury or property damage.

Failure to observe this precaution may result in unexpected failure or damage. Be sure to observe this precaution.

### <WARNING/CAUTION signs>

 <b>Warning</b>	Indicates a potentially hazardous situation which, if not avoided, could result in death or serious injury.
 <b>Caution</b>	Indicates a potentially hazardous situation which, if not avoided, may result in minor or moderate injury or property damage.

### < Prohibited & Mandatory signs >

 <b>Prohibition</b>	Prohibited: When operating the valve, this symbol indicates an action that should not be taken.
 <b>Forcing</b>	Mandatory action: When operating the valve, this symbol indicates mandatory actions that must be adhered to.

## Table of contents

<b>1. Our product warranty coverage</b> .....	<b>4</b>
Applicable to .....	4
Warranty Period .....	4
Guaranteed range.....	4
Disclaimer .....	4
<b>2. Safety Instructions</b> .....	<b>6</b>
Unpacking, Transportation and Storage .....	6
Handling of products.....	7
<b>3. Name of each part</b> .....	<b>10</b>
<b>4. Product specifications</b> .....	<b>14</b>
Model number table .....	14
Relationship between maximum allowable pressure and temperature .....	14
Actuator.....	15
Wiring Diagram .....	16
About parallel wiring .....	17
Standard option.....	17
<b>5. Piping method</b> .....	<b>18</b>
Flanged end.....	18
Threaded end.....	20
Socket end (adhesive).....	22
Socket end (fusion), spigot end (fusion).....	24
Product support.....	26
<b>6. Electrical Wiring procedure</b> .....	<b>28</b>
<b>7. Commissioning method</b> .....	<b>32</b>
Manual Operation .....	33
Electric operation .....	34
Water flow test .....	34
<b>8. Improvement of internal leakage (seat leakage)</b> .....	<b>36</b>
<b>9. How to disassemble/assemble parts for replacement</b> .....	<b>38</b>
<b>10. How to adjust the limit switch</b> .....	<b>42</b>
<b>11. How to change LED open/close indication</b> .....	<b>43</b>
<b>12. How to remove/install the actuator</b> .....	<b>44</b>
<b>13. Inspection item</b> .....	<b>46</b>
Daily inspection.....	47
Periodic inspection.....	49
<b>14. Cause of malfunction and remedy</b> .....	<b>51</b>
<b>15. How to query for faults or replacements</b> .....	<b>56</b>
<b>16. Disposal method of residual materials and waste materials</b> .....	<b>57</b>
<b>Inquiries</b> .....	<b>58</b>

## 1. Our product warranty coverage

Unless otherwise stated in the Contract or Specifications, etc., the warranty for the piping material products (hereinafter referred to as "applicable products") such as valves manufactured or sold by us is as follows.

### Applicable to

This warranty applies only when the product is used in Japan. If you intend to use the product overseas, please contact us.

### Warranty Period

The warranty period is one year after delivery.

### Guaranteed range

In the event of failure or malfunction due to our responsibility during the above warranty period, we will replace or repair the product with a substitute free of charge.

Provided, however, that even within the warranty period, the warranty shall not apply to any of the following cases (charged service).

- ▶ When the storage, operating conditions, precautions, etc. described in the specifications, instruction manual, etc. are not adhered to in the construction, installation, handling, maintenance, etc.
- ▶ Defects, such as the design of the customer's equipment or software, caused by other than the target product.
- ▶ The fault is due to modification or secondary processing of the product by something other than us.
- ▶ In the case of a failure which can be deemed to have been avoided if the periodic inspection described in the instruction manual, etc. or the maintenance or replacement of consumable parts has been performed normally.
- ▶ The component is used for purposes other than the product's intended use.
- ▶ Failure or malfunction due to causes that could not be foreseen by our level of science and technology at the time of shipment.
- ▶ The fault is due to an external factor that is not our responsibility, such as natural disaster or disaster.





### Disclaimer

- ▶ The warranty will not cover secondary damage (damage to equipment, loss of opportunity, loss of profit, etc.) or any other damage caused by the failure of our product.
- ▶ Although we strive to improve the quality and reliability of our products, we do not guarantee their integrity. Especially when using this product for equipment that may infringe human life, body or property, take appropriate safety design measures, etc., with full consideration of problems that may normally occur. We assume no responsibility for such use if we have not obtained our consent in advance in writing of specifications, etc.
- ▶ Please observe the product specifications and precautions when using our products. We shall not assume any responsibility for any damage to the customer caused by the customer's negligence. However, this does not apply to damage caused by a defect in our product.







## 2. Safety Instructions

### Unpacking, Transportation and Storage

 <b>Warning</b>	
 <b>Prohibition</b>	<p><b>Serious injury can result.</b></p> <ul style="list-style-type: none"> <li>▶ When hanging or slinging a valve, pay sufficient attention to safety, and do not enter under the load.</li> </ul>
 <b>Caution</b>	
 <b>Prohibition</b>	<p><b>The valve can be damaged, damaged, or leak.</b></p> <ul style="list-style-type: none"> <li>▶ Do not subject the product to impact by throwing, dropping or hitting.</li> <li>▶ Do not scratch or pierce the product with a sharp object such as a knife or hand hook.</li> <li>▶ Do not pile up cardboard boxes forcefully to prevent the load from collapsing.</li> <li>▶ Avoid contact with coal tar, creosote (a wood preservative), white pesticides, insecticides, paints, etc.</li> </ul>
 <b>Forcing</b>	<p><b>The valve can be damaged, damaged, or leak.</b></p> <ul style="list-style-type: none"> <li>▶ Keep in cardboard until just before piping, and store indoors (at room temperature) away from direct sunlight. Also, avoid storing the product in places of high temperature. (The strength of cardboard packaging decreases when it gets wet. Be very careful when storing and handling it.)</li> <li>▶ After unpacking, make sure that the product is correct and that it meets the specifications.</li> <li>▶ "Desiccant (silica gel)" is enclosed for the purpose of adjusting humidity inside the actuator. Do not dispose of the silica gel, but use it with it enclosed.</li> <li>▶ If the indicator on the silica gel changes color from blue to pink, replace it with a new one. Contact your dealer or your nearest office.</li> </ul>

## Handling of products

 <b>Warning</b>	
 <b>Prohibition</b>	<p><b>Serious injury can result.</b></p> <ul style="list-style-type: none"> <li>▶ Do not disassemble the actuator.</li> <li>▶ Do not touch moving parts during operation with hands, feet or tools.</li> </ul>
 <b>Forcing</b>	<p><b>The valve can be damaged or seriously injured.</b></p> <ul style="list-style-type: none"> <li>▶ If positive pressure gas is used for our resin piping material, a dangerous condition may occur due to the repulsive force peculiar to compressible fluids even if the pressure is the same as the water pressure. Therefore, be sure to take safety measures for the surrounding area, such as covering the piping with protective materials. If you have any questions, please contact us separately.</li> <li>▶ When conducting a pipe leak test after completion of piping construction, be sure to check with water pressure. Contact us in advance if you are unavoidable to test with a gas.</li> </ul> <p><b>Doing so may damage the actuator or cause serious injury.</b></p> <ul style="list-style-type: none"> <li>▶ Before use, check the power supply and voltage on the nameplate.</li> </ul>
 <b>Caution</b>	
 <b>Prohibition</b>	<p><b>The valve can be damaged, damaged, or leak.</b></p> <ul style="list-style-type: none"> <li>▶ Do not step on the valve or place heavy objects on it.</li> <li>▶ Keep away from fire and hot objects.</li> <li>▶ Do not use the product in places where it may be submerged.</li> <li>▶ Do not subject the valve to large vibrations.</li> </ul> <p><b>Doing so may damage the actuator.</b></p> <ul style="list-style-type: none"> <li>▶ The surface temperature of the actuator may rise during operation. This is due to the heat generated by the internal equipment and is not a malfunction, but do not use the product outside the allowable range of -10 to 55°C ambient temperature.</li> </ul>

 **Caution**
 **Forcing**
**There is a danger of injury.**

- ▶ Use only the tools specified by the manufacturer for manual operation.
- ▶ When performing manual operation, make sure that the actuator is not operated by the motor.
- ▶ Secure sufficient space for maintenance and inspection when piping.

**The valve can be damaged, damaged, or leak.**

- ▶ Pay attention to the atmosphere where the valve is installed. Avoid locations where the product is exposed to sea breezes, corrosive gases, chemical liquids, sea water, steam, etc.
- ▶ Keep the pressure and temperature of the fluid within the allowable range. (The maximum allowable pressure includes water hammer pressure.)
- ▶ Use a valve of suitable material for the operating conditions. (Depending on the type of chemical liquid, the parts may be damaged. Contact us in advance for details.)
- ▶ Use fluids containing crystalline material under conditions that do not recrystallize.
- ▶ Avoid any place where the valve is constantly exposed to splashes of water and dust, or direct sunlight, or protect the valve with a cover or the like to cover the entire area.
- ▶ Perform maintenance on a regular basis referring to "**13. Inspection items.**" Pay particular attention to temperature changes and aging during long-term storage or shutdown or use.
- ▶ When installing a valve, provide an appropriate valve support so that excessive force is not applied to the valve and piping.
- ▶ Always use the product within the indicated product specifications.
- ▶ If the valve is used at an intermediate position, a mark of the ball opening may remain on the seat (PTFE), and the sealing performance may drop temporarily when the valve is fully closed to the left or fully closed to the right. Therefore, it is recommended to use the valve in fully opened left or fully opened right.

**Doing so may damage the base plate.**

- ▶ When removing the actuator from the valve body, be sure to use the base plate removal jig (optional item).

**Doing so may damage the actuator.**

- ▶ If you notice an unusual odor, heat, or smoke, immediately turn off the power supply. If any abnormality is found, be sure to consult your dealer or us for inspection.
- ▶ Keep the ambient temperature of the installation location within -10 to 55°C.
- ▶ Avoid locations with volatile gases or poor atmospheres. Provide a cover, etc., to cover the entire area.



## ⚠ Caution

**Please confirm.**

- ▶ "P1", "P2", "P3" stickers are affixed to the sides of the body.  
"P1" indicates left open side, "P2" indicates right open side, and "P3" indicates normally open.



**3. Name of each part**

Nominal diameter 15~50mm

Exploded view

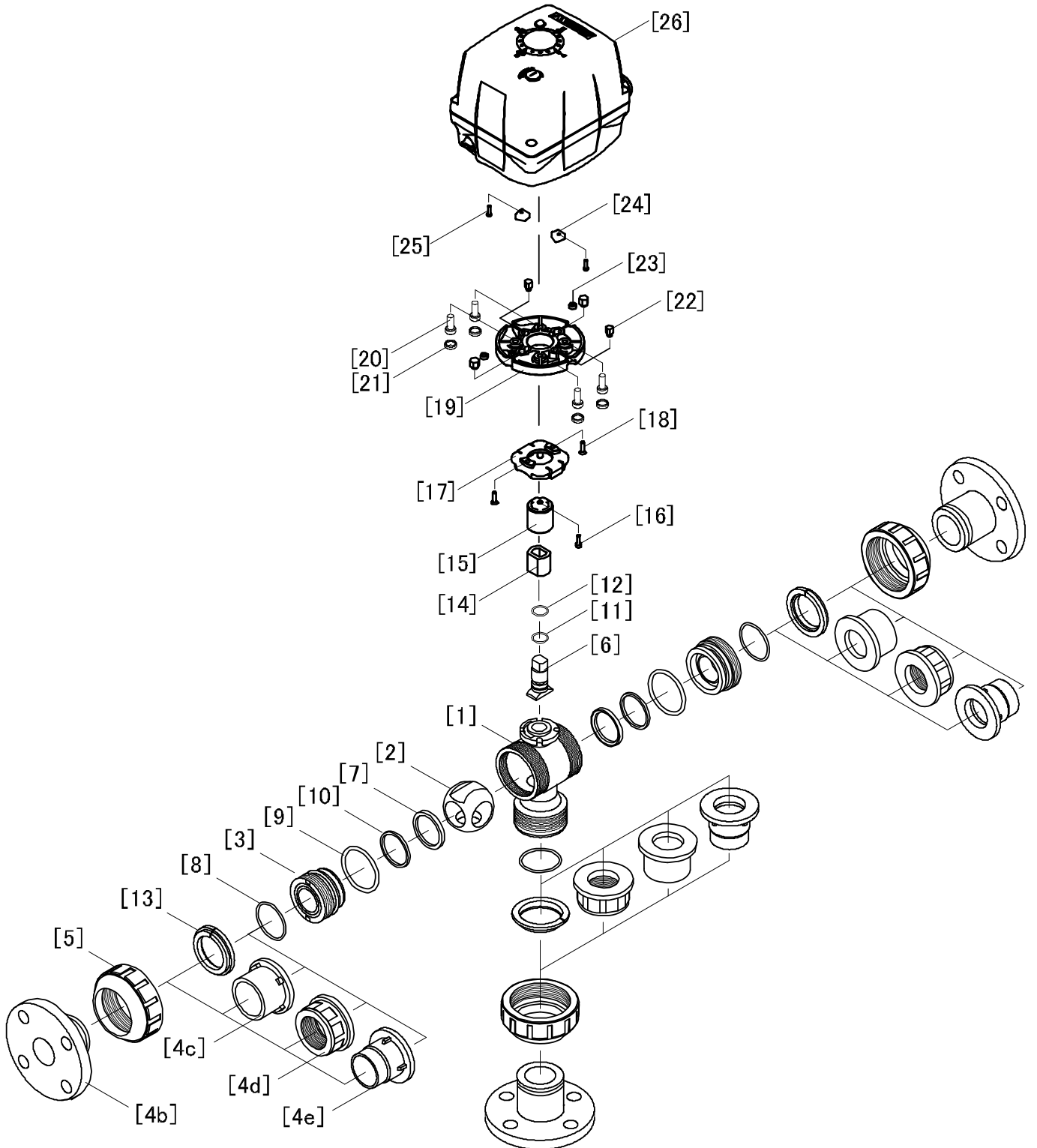

## Valve parts list

No.	Name	No.	Name	No.	Name
[1]	Body	[8]	O-ring (A)	[18]	Bolt
[2]	Ball	[9]	O-ring (B)	[19]	Connector plate
[3]	Carrier	[10]	O-ring (C)	[20]	Bolt
[4b]	End connector (Flanged end)	[11]	O-ring (D)	[21]	Rubber cap
[4c]	End connector (Socket end)	[12]	O-ring (E)	[22]	Rubber cap
[4d]	End connector (Threaded end)	[13]	Stop ring	[23]	Nut
[4e]	End connector (Spigot end)	[14]	Adapter	[24]	Stopper
[5]	Union nut	[15]	Bush	[25]	Tapping screw
[6]	Stem	[16]	Bolt	[26]	Actuator
[7]	Seat	[17]	Base plate		

## Actuator structure

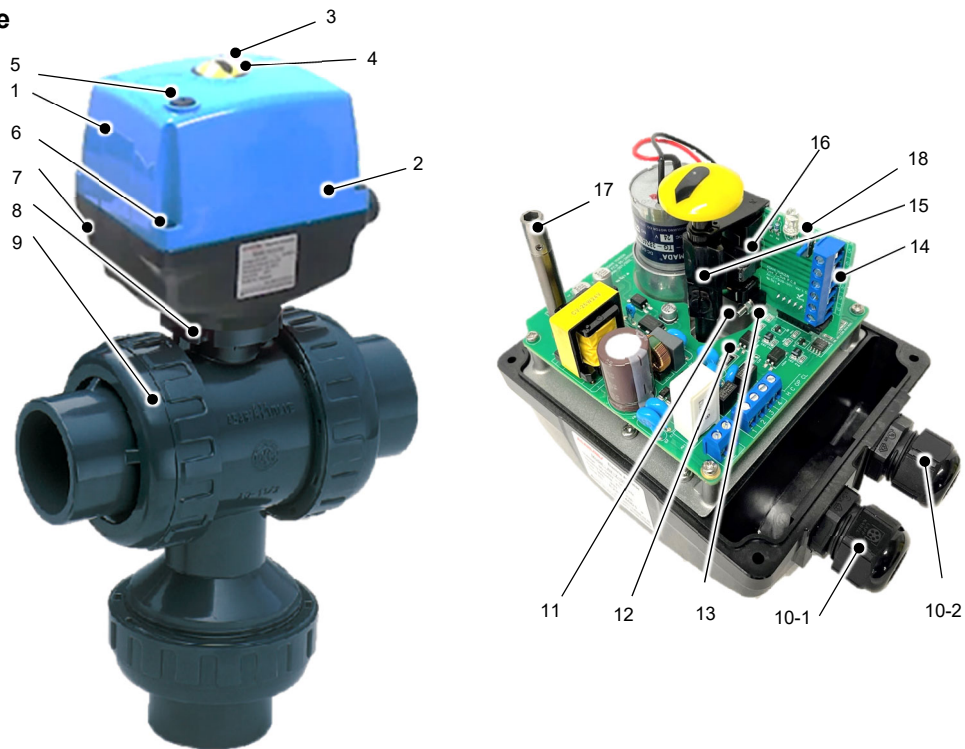

## Actuator parts list

No.	Name
1	Cover
2	Body
3	LED light
4	Indicator
5	Bushing for manual operation
6	Bolt cap
7	Auto/Manual Selector
8	Base plate
9	Valve
10-1	Cable gland for power line input (sponge type dust seal included)
10-2	Cable gland for signal-line outputting (with NBR ceiling plug)
11	Space heater
12	Grounding terminal block
13	Terminal block for power input
14	Terminal block for signal output
15	Limit cam for left/right opening
16	Limit switch for limit/output
17	Shaft for manual operation (with hexagon socket)
18	Open/close indication LED color selector



## 4. Product specifications

### Model number table

Actuation	Valve type	Actuator type	Voltage	Body material	Seal material	Connection	Standard	Size	High Purity Series
A	23	Z	U	*	*	*	*	* * *	*
A Automatic	23 Type 23	Z Type Z	U 95~240VAC	U U-PVC C C-PVC P PP F PVDF	E EPDM V FKM	F Flanged S Socket N Threaded P Spigot	J JIS 1 JIS10K 5 JIS5K D DIN A ANSI	015 15mm (1/2") 020 20mm (3/4") 025 25mm (1") 032 32mm (1 1/4") 040 40mm (1 1/2") 050 50mm (2")	Non Standard 1 Lubricant Free

### NOTE

- JIS standard socket end of the body material PVDF is not manufactured.
- JIS standard socket end 32mm with PP body material is not manufactured.
- Connecting method Spigot end is only DIN standard and body material C-PVC is not manufactured.

### Relationship between maximum allowable pressure and temperature

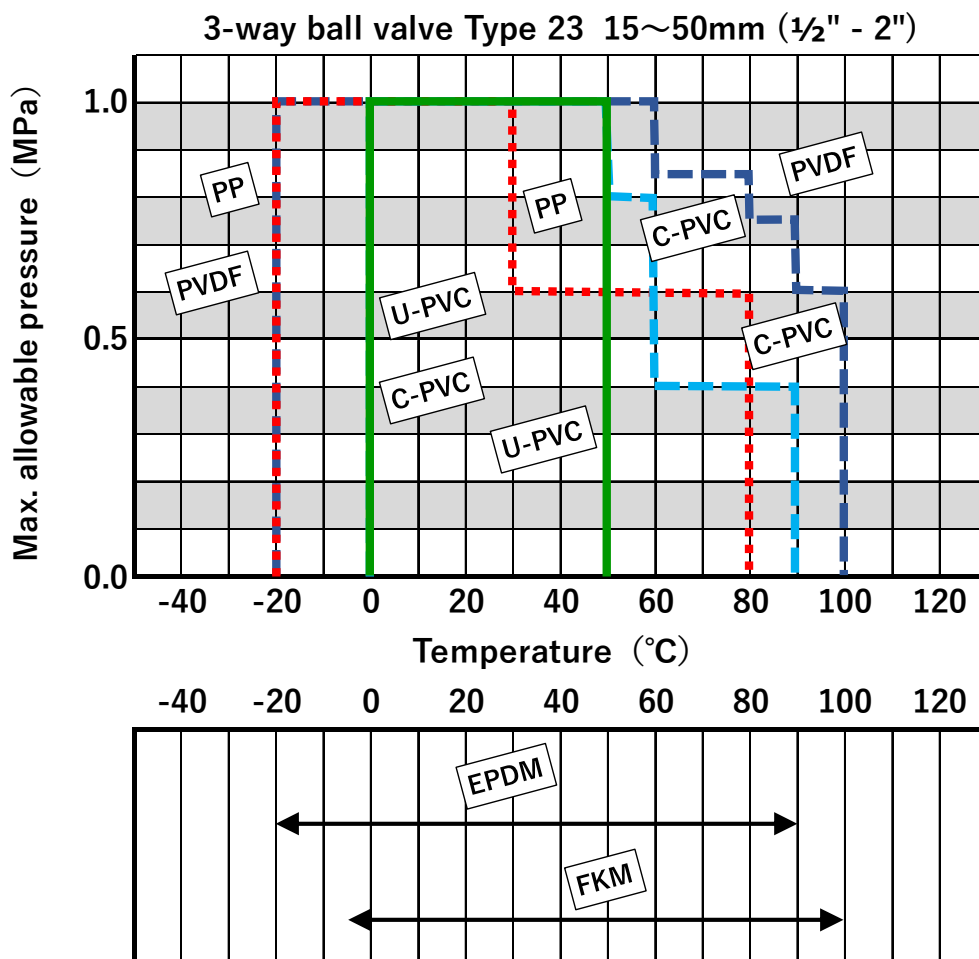

## Actuator

Applicable size		15~50mm (1/2"-2")
Actuator model		AV-Z-025
Rated torque *1)		10 N-m
Maximum output torque		25 N-m
Rated voltage *2)		AC 95~240V ± 10% 50/60Hz (universal power supply)
Power consumption		17VA
Motor protection *3)		Overcurrent protection device
Operating area (Min-Max)		0° to 90° (maximum operating angle 110°:-10° to 100°)
Open/close time (no load, with load)		8 seconds/90°, 9 seconds/90°
External dimensions		W175(145)×D120×H150mm [(145) excluding cable gland]
Weight		1.7kg
Operating environment	Installation Environment *4)	Indoor and outdoor (constrained/conditioned)
	Protection grade	IP67
	Pollution degree	2
	Ambient temperature	-10 to 55°C (no freezing or condensation)
Duty cycle (Duty cycle) *1)		30%
Wiring port	Cable gland	Power input/signal output, 1 each. CE / VDE standard product
	Terminal block	Screw type, applicable wire: O.D. φ7~13mm, wire size 0.75~2.0mm <sup>2</sup>
Housing material		Cover: Polycarbonate (Blue) Flame-resistant UL94V-0 Body: Glass-blended polycarbonate (black) Flame-resistant UL94V-0
Function	Status output *5)	One contact (no-voltage contact) for fully open left and fully open right, contact capacitance Max.250VAC-1A
	Status display *6)	Indicator/LED light (green: left open position, red: right open position)
	Manual Operation	With Auto/Manual selector. 9 turns/90° with an Allen wrench
	Space heater	Rated power 5W (function only when energized)
Insulation resistance		500VDC, 10MΩ or more
Withstand voltage		1500VAC, 1 minute

\*1) Loads and Duty cycle are as per S4 (IEC60034-1 equivalent to bulb loads).

\*2) The length of the power line cable should be within 100 meters as a guideline.

\*3) In case of an overload, the thermistor functions and the power to the motor is cut off. (Self-restoration occurs when the power supply is cut off.)

\*4) This actuator can be used in IP67 environments. However, when opening the housing for maintenance/adjustment, etc., it should be done in a pollution degree 2 environment (e.g. indoors, etc., in an environment free from dust and moisture).

\*5) Keep the devices connected to the limit switch (non-voltage contact) for the left open/right open signal within the contact capacitance (1A). (Risk of damage)

\*6) LED (Green: left open, Red: right open) is factory-set. The color can be changed with the selector switch in the actuator.

## Wiring Diagram



**Caution**



**Prohibition**

**Failure to do so may cause seat leakage.**

▶ Do not stop the power supply by the operation of the contact limit switch.

• Reference Wiring Example

- OLS-1 : Left open limit switch
- SLS-1 : Right open limit switch
- OLS-2 : Left open contact switch
- SLS-2 : Right open contact switch
- M : Motor

The wiring diagram shows the end of the left open operation

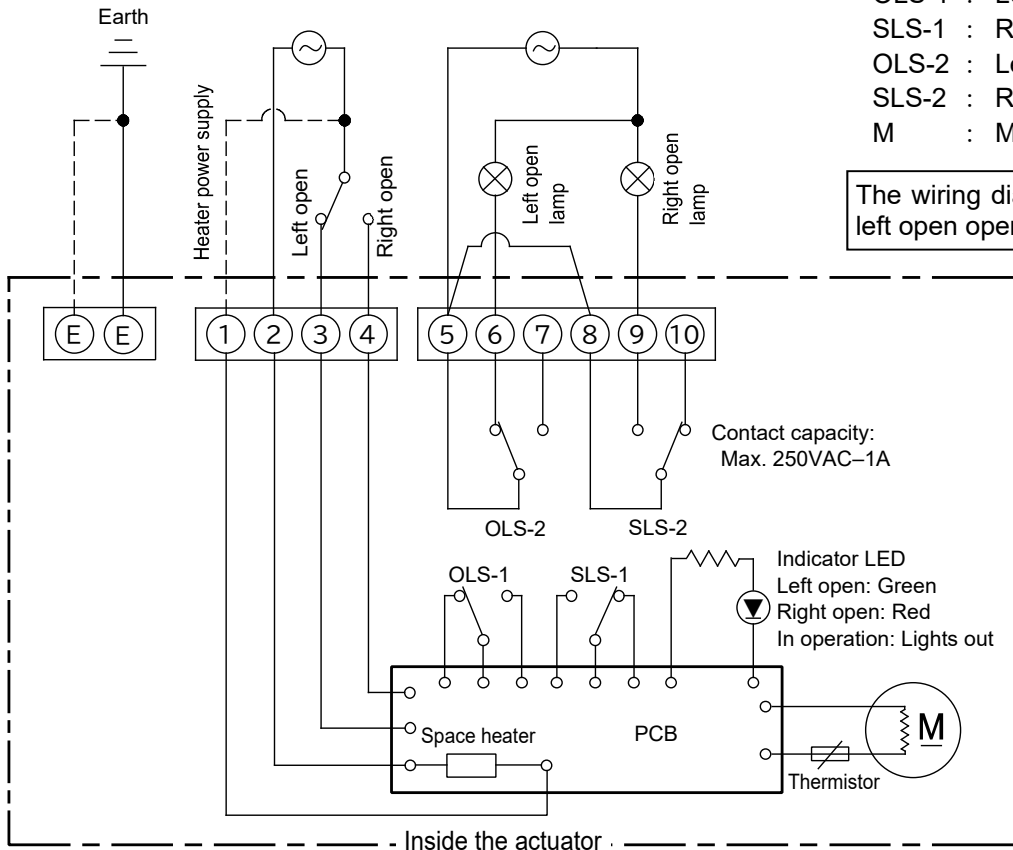

### Switching chart

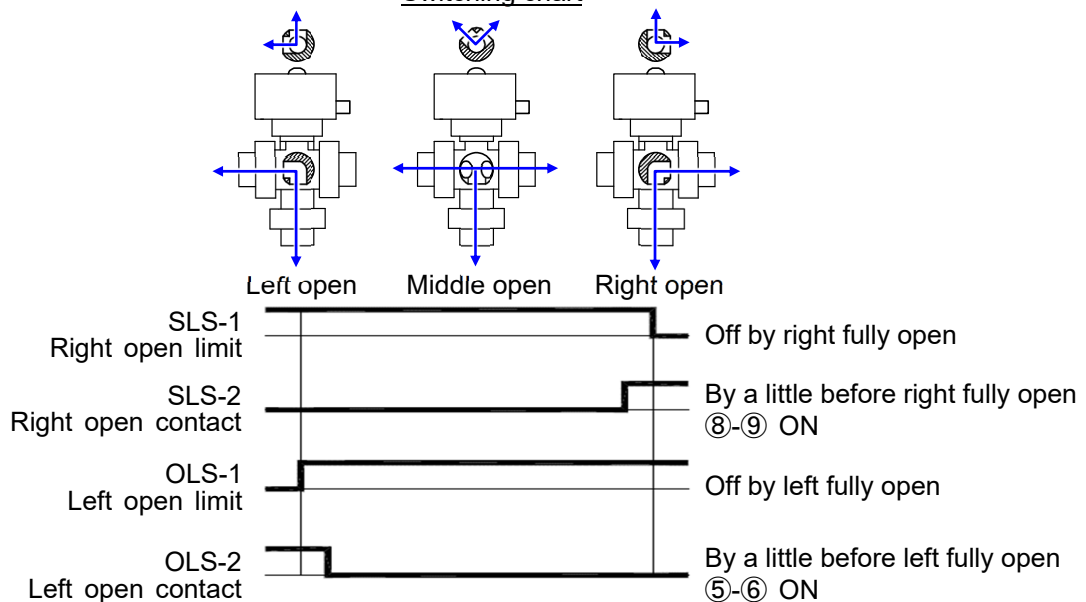

- The contact limit switch is set approximately 8 degrees before the motor stop position.
- If the valve stops operating with the contact limit switch, the valve will not close completely and may cause a leak.



## About parallel wiring

If several (two or more) motorized valves are connected in parallel and operated simultaneously with a single open/close switch (or relay contact), there is a possibility of malfunction. In this condition, the actuator may be damaged. Do not connect wires like this. (See Fig. 4-1.)

Provide an open/close switch (or relay contact) for each unit to ensure correct operation. (See Fig. 4-2.)

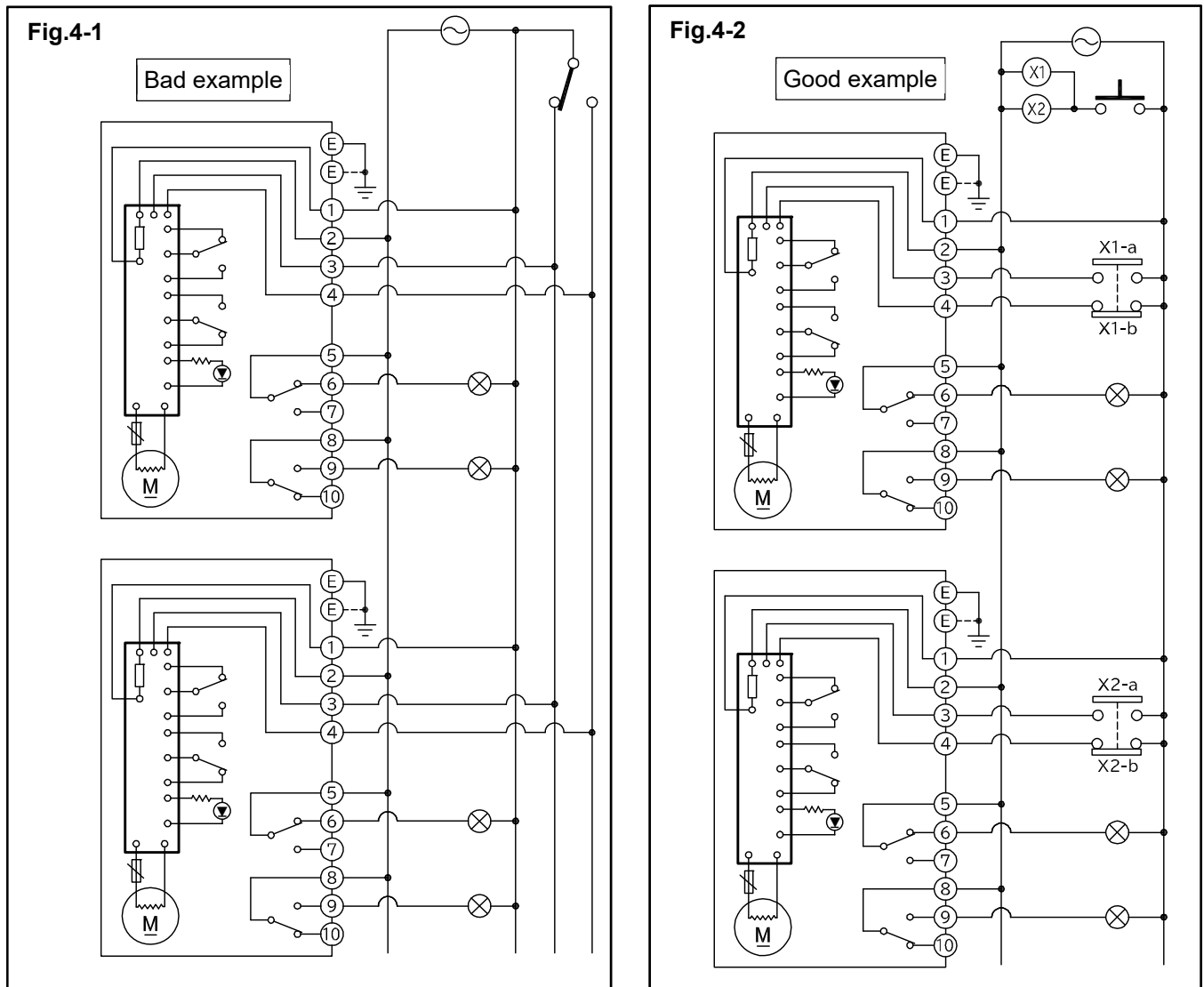



## Standard option



Option name	Objectives and specifications	Applicable size
Micro-load specification No-voltage limit switch	<ul style="list-style-type: none"> <li>• Input to PLC, etc.</li> <li>• 1mA~100mA, 5VDC~30VDC</li> </ul>	15~50mm (1/2"-2")

Contact us for other special options, etc.

## 5. Piping method

### Flanged end

 <b>Warning</b>	
 <b>Prohibition</b>	<p><b>Serious injury can result.</b></p> <ul style="list-style-type: none"> <li>▶ When hanging or slinging a valve, pay sufficient attention to safety, and do not enter under the load.</li> </ul>
 <b>Forcing</b>	<p><b>There is a risk of electric shock or injury.</b></p> <ul style="list-style-type: none"> <li>▶ Be sure to perform safety inspections of the machine tool and power tool beforehand.</li> <li>▶ Wear appropriate protective equipment according to the type of work being performed.</li> </ul>

 <b>Caution</b>	
 <b>Prohibition</b>	<p><b>The valve can be damaged, or leak.</b></p> <ul style="list-style-type: none"> <li>▶ Do not overtighten the union nut.</li> <li>▶ Do not use a pipe wrench to tighten the union nut.</li> <li>▶ Do not tighten piping bolts and nuts with more than the torque value shown in "<b>Table 5-2 Flange tightening torque values</b>".</li> </ul>
 <b>Forcing</b>	<p><b>The valve can be damaged, or leak.</b></p> <ul style="list-style-type: none"> <li>▶ Install the product so that excessive stress such as tension, compression, bending or impact is not applied to the piping or valve.</li> <li>▶ Fix the end connector during piping work or disassembly and reassembly.</li> <li>▶ When attaching the valve to the end of the pipe, be sure to attach the union nut and end connector on the secondary side (downstream side).</li> <li>▶ When connecting to metal piping, do not apply piping stress to the valve.</li> <li>▶ Use a connection flange with a full-face seat.</li> <li>▶ Check that there is no difference in mutual flange standards.</li> <li>▶ Be sure to use a sealing gasket (AV packing) between the flanges and tighten the pipe bolts/nuts to the specified torque values in <b>Table 5-2</b> "Flange tightening torque." (When other than AV packing, the tightening torque value will change.)</li> <li>▶ Keep the axis misalignment and parallelism of the flange surface below the values shown in <b>Table 5-1</b> "Axis misalignment and parallelism."</li> <li>▶ Tighten the bolts and nuts for piping diagonally with the specified torque values in <b>Table 5-2</b>.</li> </ul>

Necessary item	▶ Torque wrench	▶ Spanner or an eyeglass wrench	▶ Belt Wrench
	▶ Piping bolts, nuts, and washers	▶ AV packing	▶ Waste cloth

**[Procedure]**

- 1) Clean mutual flange surfaces with a waste cloth.
- 2) Set AV packing between the flanges.
- 3) Insert the washer and bolt from the connecting flange side. Insert the washer and nut from the valve side and tighten temporarily by hand.
- 4) Set the axis misalignment and parallelism of the flange surface below the values shown in **Table 5-1**, "Axis misalignment and parallelism." (See **Fig. 5-1**.)
- 5) Using a torque wrench, gradually tighten the screws diagonally to "**Table 5-2 Flange Tightening Specified Torque Values**". (See **Fig. 5-2**.)
- 6) Tighten it more than two turns clockwise with "**Table 5-2 Flange Tightening Torque Specified Values**". (See **Fig. 5-2**.)
- 7) When it is necessary to loosen or remove the union nut for construction reasons, follow the procedure below to tighten **the union nut**.
  - 7-1) Make sure that the O-ring (A) is installed in the body correctly.
  - 7-2) Bring the end connector and union nut into contact with the body side so that the O-ring (A) does not come off.
  - 7-3) Tighten the union nut by hand until it is tight.
  - 7-4) Screw in the union nut by 1/4 to 1/2 turn with a belt wrench to prevent damage to the union nut.

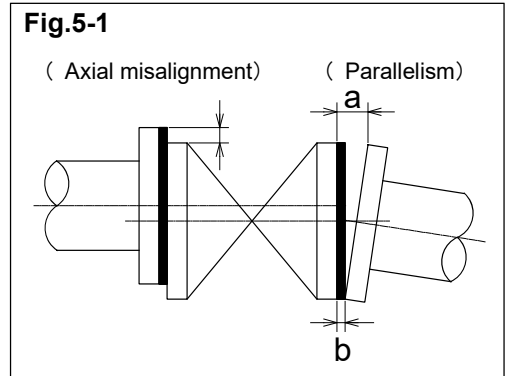

**Table 5-1 Axis misalignment and parallelism**

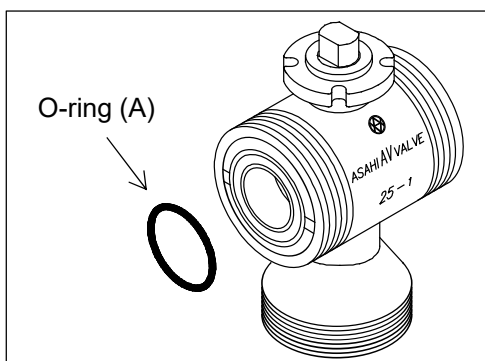
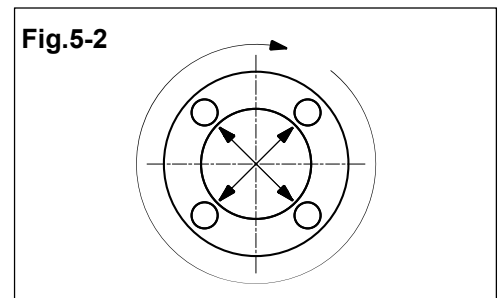

Nominal diameter	Shaft misalignment	Parallelism (a-b)
15mm	1.0 mm	0.5 mm
20mm		
25mm		
32mm	1.0 mm	0.8 mm
40mm		
50mm		





**Table 5-2 Flange tightening torque**

Nominal diameter	PTFE coating	PVDF coating	Rubber
15mm	17.5 N-m	17.5 N-m	8.0 N-m
20mm			
25mm	20.0 N-m	20.0 N-m	20.0 N-m
32mm			
40mm	22.5 N-m	22.5 N-m	22.5 N-m
50mm			

## Threaded end

 <b>Warning</b>	
 <b>Prohibition</b>	<p><b>Serious injury can result.</b></p> <ul style="list-style-type: none"> <li>▶ When hanging or slinging a valve, pay sufficient attention to safety, and do not enter under the load.</li> </ul>
 <b>Forcing</b>	<p><b>There is a risk of electric shock or injury.</b></p> <ul style="list-style-type: none"> <li>▶ Be sure to perform safety inspections of the machine tool and power tool beforehand.</li> <li>▶ Wear appropriate protective equipment according to the type of work being performed.</li> </ul>

 <b>Caution</b>	
 <b>Prohibition</b>	<p><b>The valve can be damaged, or leak.</b></p> <ul style="list-style-type: none"> <li>▶ Do not overtighten the screws on the connections.</li> <li>▶ Do not overtighten the union nut.</li> <li>▶ Do not use a pipe wrench to tighten the union nut.</li> </ul>
 <b>Forcing</b>	<p><b>The valve can be damaged, or leak.</b></p> <ul style="list-style-type: none"> <li>▶ The union nut of this product is lightly tightened to make it easier to loosen. Be sure to remove the end connector before installation.</li> <li>▶ Install the product so that excessive stress such as tension, compression, bending or impact is not applied to the piping or valve.</li> <li>▶ Fix the end connector during piping work or disassembly and reassembly.</li> <li>▶ When attaching the valve to the end of the pipe, be sure to attach the union nut and end connector on the secondary side (downstream side).</li> <li>▶ When connecting to metal piping, do not apply piping stress to the valve.</li> <li>▶ Make sure that the screws at the joints are made of resin.</li> <li>▶ Use sealing tape for the sealing material of the screw-in part. If liquid sealant or liquid gasket is used, stress cracking (environmental stress cracking) may occur.</li> </ul>



Necessary items	▶ Sealing tape	▶ Belt Wrench	▶ Spanner or motor wrench
-----------------	----------------	---------------	---------------------------

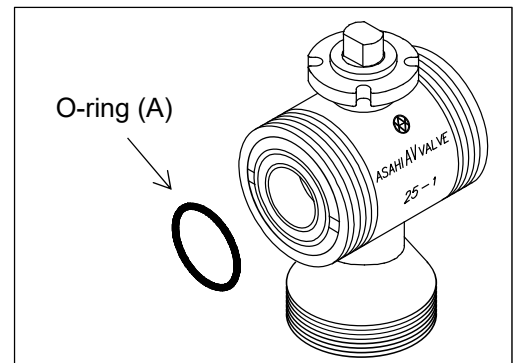
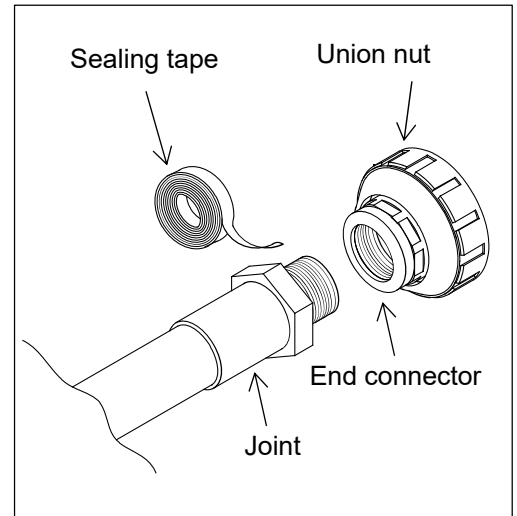

## [Procedure]

- 1) Wrap sealing tape around the male thread of the fitting, leaving approximately 3mm at the end.
- 2) Loosen the union nut by hand.
- 3) Remove the union nut and end connector from the body.
- 4) Tighten the male thread of the fitting and the end connector until tight.
- 5) Screw in with a wrench or a motor wrench 1/2 to 1 turn to prevent damage to the end connector.
- 6) Check that the O-ring (A) is correctly installed in the body.
- 7) Bring the end connector and union nut into contact with the body side so that the O-ring (A) does not come off.
- 8) Tighten the union nut by hand until it is tight.
- 9) Screw in the union nut by 1/4 to 1/2 turn with a belt wrench to prevent damage to the nut.



Socket end (adhesive)

 <b>Warning</b>	
 <b>Prohibition</b>	<p><b>Serious injury can result.</b></p> <ul style="list-style-type: none"> <li>▶ When hanging or slinging a valve, pay sufficient attention to safety, and do not enter under the load.</li> </ul> <p><b>Fire or an explosion can result.</b></p> <ul style="list-style-type: none"> <li>▶ Ensure adequate ventilation when using adhesives and do not use open flames around them.</li> </ul>
 <b>Forcing</b>	<p><b>Electric shock or There is a danger of injury.</b></p> <ul style="list-style-type: none"> <li>▶ Be sure to perform safety inspections of the machine tool and power tool beforehand.</li> <li>▶ Wear appropriate protective equipment according to the type of work being performed.</li> </ul>

 <b>Caution</b>	
 <b>Prohibition</b>	<p><b>There is a danger of injury.</b></p> <ul style="list-style-type: none"> <li>▶ The adhesive contains volatile solvents, so do not inhale odors directly.</li> </ul> <p><b>The valve can be damaged, or leak.</b></p> <ul style="list-style-type: none"> <li>▶ Do not apply too much adhesive. Excessive adhesive will flow into the valve.</li> <li>▶ Do not strike the pipe when inserting it into the end connector.</li> <li>▶ Do not overtighten the union nut.</li> <li>▶ Do not use a pipe wrench to tighten the union nut.</li> </ul>
 <b>Forcing</b>	<p><b>There is a danger of injury.</b></p> <ul style="list-style-type: none"> <li>▶ If the adhesive adheres to the skin, remove it immediately.</li> <li>▶ If you feel worse or feel unusual when using the adhesive, promptly seek a doctor's diagnosis and take appropriate action.</li> </ul> <p><b>The valve can be damaged, or leak.</b></p> <ul style="list-style-type: none"> <li>▶ The union nut of this product is lightly tightened to make it easier to loosen. Be sure to remove the end connector before installation.</li> <li>▶ Install the product so that excessive stress such as tension, compression, bending or impact is not applied to the piping or valve.</li> <li>▶ Fix the end connector during piping work or disassembly and reassembly.</li> <li>▶ When attaching the valve to the end of the pipe, be sure to attach the union nut and end connector on the secondary side (downstream side).</li> <li>▶ Be careful when constructing under low temperature, as solvent vapor is less likely to evaporate and tends to remain.</li> <li>▶ After piping, open both ends of the pipe and use a blower (low-pressure type) to ventilate to remove the solvent vapor.</li> <li>▶ Use "ASAHI AV adhesive" depending on the material.</li> <li>▶ Perform the water flow test after 24 hours or more have elapsed after completion of bonding.</li> </ul>

Necessary items	▶ ASAHI AV cement	▶ Belt Wrench	▶ Waste cloth
-----------------	-------------------	---------------	---------------

### [Procedure]

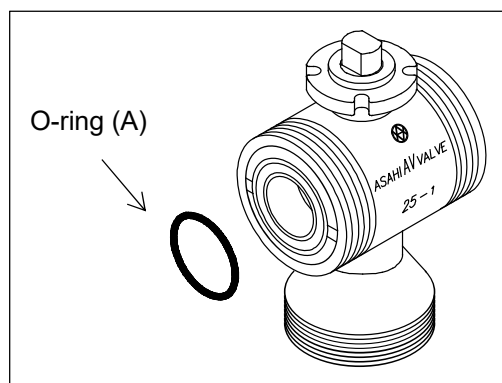
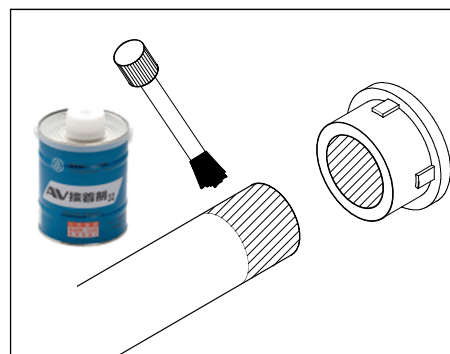

- 1) Loosen the union nut by hand.
- 2) Remove the union nut and end connector from the body.
- 3) Pass the union nut to the pipe side.
- 4) Wipe off the insertion part of the pipe and the socket part of the end connector with a waste cloth.
- 5) Refer to "**Table 5-3 Adhesive Consumption (Reference)**" and apply adhesive evenly in the order of the socket part of the end connector and the pipe insertion part.
- 6) After applying the adhesive, quickly insert the pipe into the end connector and hold it as is for at least 60 seconds.
- 7) Wipe off any excess adhesive with a waste cloth.
- 8) Check that the O-ring (A) is correctly installed in the body.
- 9) Bring the end connector into contact with the body so that the O-ring (A) does not come off.
- 10) Tighten the union nut by hand until it is tight.
- 11) Screw in the union nut by 1/4 to 1/2 turn with a belt wrench to prevent damage to the nut.





**Table 5-3. Adhesive Consumption (Reference)**

Nominal size	Volume used
15mm	1.0 g
20mm	1.3 g
25mm	2.0 g
32mm	2.4 g
40mm	3.5 g
50mm	4.8 g

## Socket end (fusion), spigot end (fusion)

 <b>Warning</b>	
 <b>Prohibition</b>	<p><b>Serious injury can result.</b></p> <ul style="list-style-type: none"> <li>▶ When hanging or slinging a valve, pay sufficient attention to safety, and do not enter under the load.</li> </ul>
 <b>Forcing</b>	<p><b>Electric shock or There is a danger of injury.</b></p> <ul style="list-style-type: none"> <li>▶ Be sure to perform safety inspections of the machine tool and power tool beforehand.</li> <li>▶ Wear appropriate protective equipment according to the type of work being performed.</li> </ul>

 <b>Caution</b>	
 <b>Prohibition</b>	<p><b>The valve can be damaged, or leak.</b></p> <ul style="list-style-type: none"> <li>▶ Do not overtighten the union nut.</li> <li>▶ Do not use a pipe wrench to tighten the union nut.</li> </ul>
 <b>Forcing</b>	<p><b>The valve can be damaged, or leak.</b></p> <ul style="list-style-type: none"> <li>▶ The union nut of this product is lightly tightened to make it easier to loosen. Be sure to remove the end connector before installation.</li> <li>▶ Install the product so that excessive stress such as tension, compression, bending or impact is not applied to the piping or valve.</li> <li>▶ Fix the end connector during piping work or disassembly and reassembly.</li> <li>▶ When attaching the valve to the end of the pipe, be sure to attach the union nut and end connector on the secondary side (downstream side).</li> </ul>

Necessary items	▶ Belt Wrench	▶ Fusing machine	▶ Instruction manual of the fusing machine
-----------------	---------------	------------------	--

### [Procedure]

- 1) Loosen the union nut by hand.
- 2) Remove the union nut and end connector from the body.
- 3) Pass the union nut to the pipe side.
- 4) From here, refer to the instruction manual of the fusing machine for fusing.
- 5) Check that the O-ring (A) is correctly installed in the body.
- 6) Bring the end connector into contact with the body so that the O-ring (A) does not come off.
- 7) Tighten the union nut by hand until it is tight.
- 8) Screw in the union nut by 1/4 to 1/2 turn with a belt wrench to prevent damage to the nut.

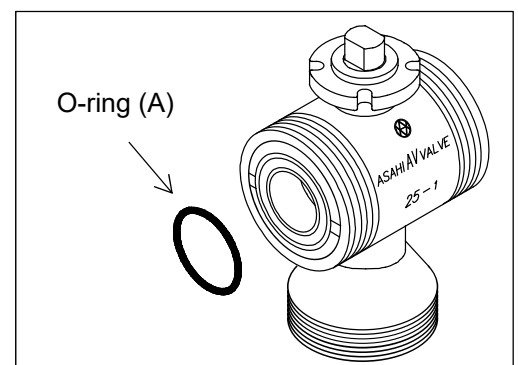





Product support

## Warning



### Forcing

**Electric shock or There is a danger of injury.**

- ▶ Be sure to perform safety inspections of the machine tool and power tool beforehand.
- ▶ Wear appropriate protective equipment according to the type of work being performed.

## Caution



### Prohibition

**The valve can be damaged, or leak.**

- ▶ Do not over-tighten when supporting piping with a U-band, etc.
- ▶ When installing a valve in the piping around the pump, do not cause large vibrations in the valve.

Necessary items	▶ Wrench	▶ Rubber sheet
	▶ U-band (with bolt)	▶ Nut / Washer

### ▶ Support valve and piping (horizontal piping)

#### [Procedure]

- 1) For flange type, lay the rubber sheet on the flange part of the valve. Lay a rubber sheet on top of the pipe section if it is not a flange type.
- 2) Put the U-band over the rubber sheet and secure it to the frame with the nut.



### ▶ Support valve and piping (vertical piping)

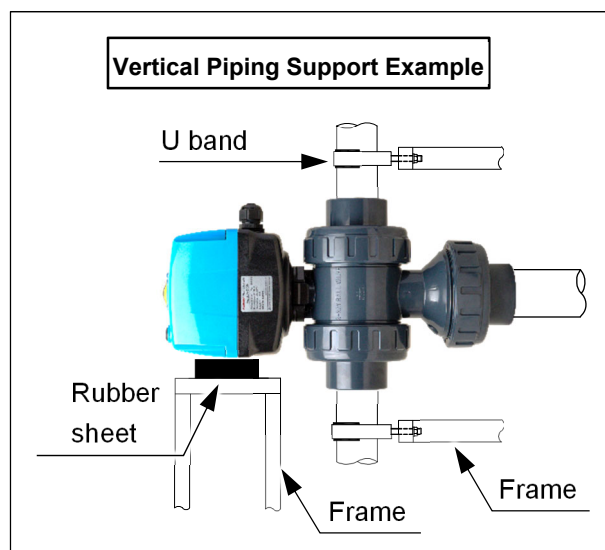
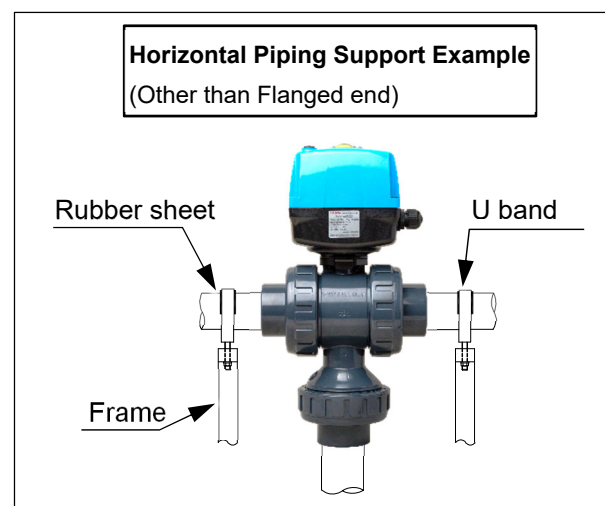
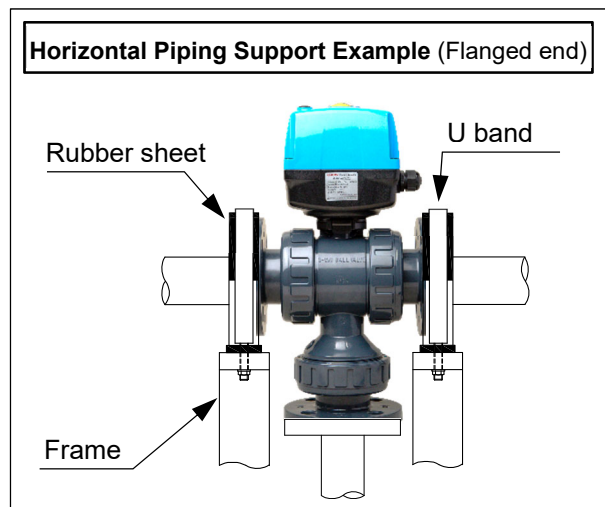

#### [Procedure]

- 1) For flange type, lay the rubber sheet on the flange part of the valve. Lay a rubber sheet on top of the pipe section if it is not a flange type.
- 2) Put the U-band over the rubber sheet and secure it to the frame with the nut.
- 3) Place the rubber sheet between the actuator and the frame.



## 6. Electrical Wiring procedure

 <b>Warning</b>	
 <b>Prohibition</b>	<p><b>There is a risk of electric shock.</b></p> <ul style="list-style-type: none"> <li>▶ Do not perform wiring while the power is on.</li> <li>▶ Do not touch any other parts on the board or the terminal block wiring part.</li> <li>▶ Do not perform wiring work in an environment where rain water or moisture may splash on the wiring work (e.g. outdoor work in rainy weather).</li> <li>▶ Do not perform wiring work with wet hands or tools.</li> </ul>
 <b>Forcing</b>	<p><b>Electric shock or There is a danger of injury.</b></p> <ul style="list-style-type: none"> <li>▶ Be sure to perform safety inspections of the machine tool and power tool beforehand.</li> <li>▶ Wear appropriate protective equipment according to the type of work being performed.</li> </ul>

 <b>Caution</b>	
 <b>Prohibition</b>	<p><b>Doing so may cause the actuator to fail or malfunction.</b></p> <ul style="list-style-type: none"> <li>▶ Do not apply a load to the non-voltage limit switch exceeding the contact capacity.</li> <li>▶ Do not connect multiple (two or more) motorized valves in parallel.</li> <li>▶ Do not use the product near high-voltage lines, inverters, or other objects that generate noise or magnetism.</li> <li>▶ Do not remove the sealing plug supplied with the cable gland if you are not wiring the signal wire.</li> </ul>
 <b>Forcing</b>	<p><b>There is a risk of electric shock or injury.</b></p> <ul style="list-style-type: none"> <li>▶ Keep hands free of moisture and oil during operation.</li> </ul> <p><b>Doing so may cause the actuator to fail or malfunction.</b></p> <ul style="list-style-type: none"> <li>▶ Provide a left open/right open switch (or relay contact) for each motorized valve.</li> <li>▶ Be sure to connect the ground wire.</li> <li>▶ Connect the wires correctly according to the wiring diagram.</li> <li>▶ Perform the wiring work without insulation failure.</li> <li>▶ Tighten the terminal block with the recommended tightening torque (0.15~0.18 N-m) so that there is no looseness.</li> <li>▶ Connect the wires so that the conductors of the lead wires do not come into contact with each other.</li> <li>▶ Tighten the cable gland securely with the recommended tightening torque (3 N-m).</li> <li>▶ The cover of the actuator is sealed by an O-ring. When removing and reinstalling the cover for wiring work, etc., make sure that the O-ring is set in place.</li> <li>▶ Tighten the screws to attach the cover of the actuator with the recommended tightening torques (1N-m).</li> <li>▶ Securely tighten the cable gland when it is used outdoors or in a place where it will be exposed to rain water or water drops.</li> <li>▶ After wiring, make sure that the screws (crimp terminals, etc.) are not tightened or loosened.</li> <li>▶ This product supports universal power supply. Use the product within the specified power supply voltage.</li> </ul>

**⚠ Caution**

**Doing so may cause the actuator to fail or malfunction.**

- ▶ The non-voltage limit switch does not support minute loads (for example, when connecting to a 1mA~100mA, 5V~30V, PLC) in the standard product. Select and use an optional product.
- ▶ Keep the devices connected to the limit switch (non-voltage contact) for the left open/right open signal within the contact capacitance (1A).
- ▶ Use a power line of 100 meters or less for connection as a guide.
- ▶ When the distance from the switchboard to the actuator exceeds 100 meters, connect between them through a relay (mechanical relay) to make the distance from the relay to the actuator 100 meters or less.

**! Forcing**

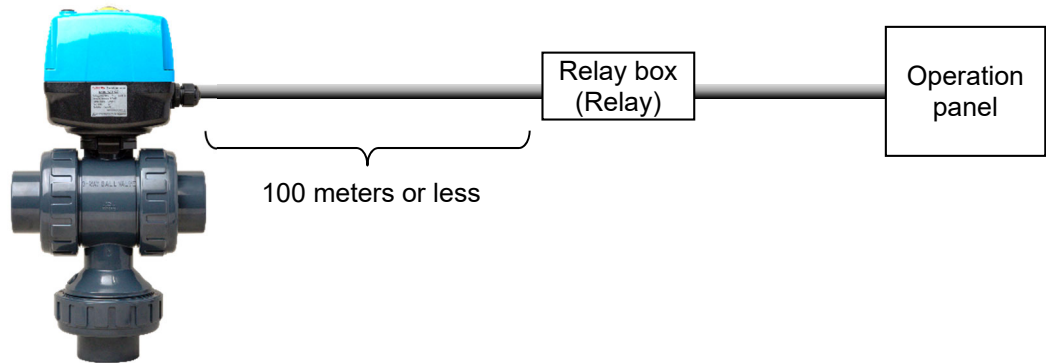

Necessary items	▶ Phillips screwdriver	▶ Flat-blade screwdriver (Precision)	▶ Electric knife
	▶ Wire stripper	▶ wrench	▶ crimp pliers
			▶ bar terminal

**[Procedure]**

- 1) Remove the four bolt caps on the cover. (See Fig. 6-1. Be careful not to lose the bolt cap.)
- 2) Loosen the four screws securing the cover with a Phillips screwdriver and remove the cover.
- 3) Remove the dust seal and sealing plug from the cable gland and thread the cable. (See Fig. 6-2.)
- 4) Strip the insulation of the cable sheath and the lead wire with an electric knife and wire stripper.
- 5) Attach the ferrule to the tip of the lead wire with a crimp pliers. When wiring without ferrules, twist the end of the lead wire so that no beard comes out.
- 6) Follow the wiring diagram and use a flathead screwdriver (precision) to connect the ferrule terminal (or the end of the lead wire) to the terminal block with the recommended tightening torque 0.15~0.18 N-m. (See Fig. 6-3. Either of the two ground terminals can be used.)
- 7) Secure the cable by tightening the cable gland with a wrench to the recommended tightening torques 3N-m. (See Fig. 6-4.)
- 8) Orient the removed cover according to the "Alignment of the shaft for manual operation" as a guide and install it.
- 9) Tighten the four screws securing the cover with a Phillips screwdriver diagonally with the recommended tightening torque 1N-m to attach the bolt cap.

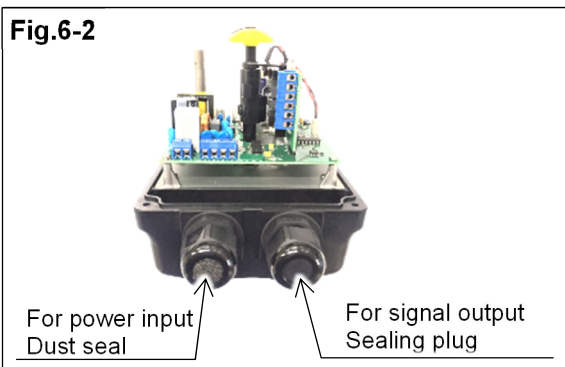
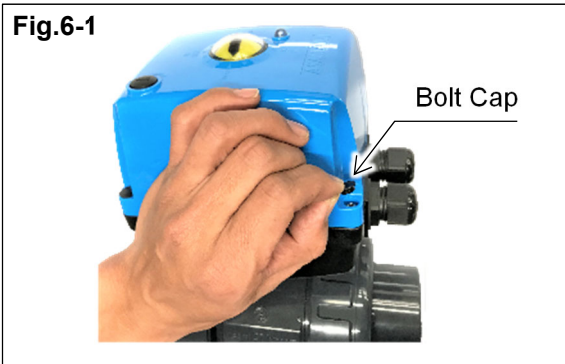

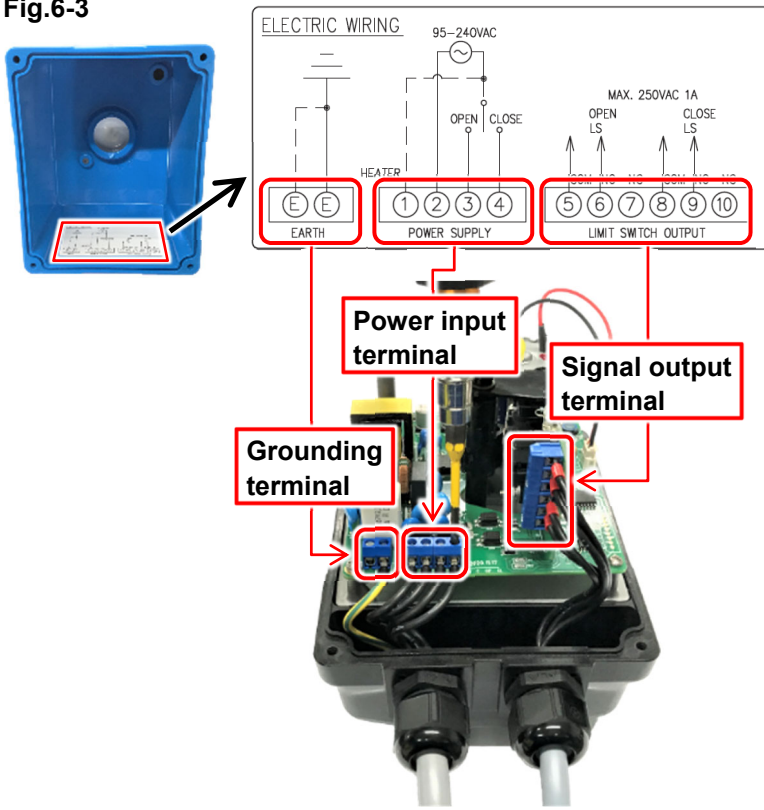

**Fig.6-3**





**Fig.6-4**



## 7. Commissioning method

 <b>Warning</b>	
 <b>Prohibition</b>	<p><b>Serious injury can result.</b></p> <ul style="list-style-type: none"> <li>▶ Insulation-resistance DC500V, 10MΩ. Do not apply high voltage considering the actuator specifications below the withstanding voltage 1500VAC, 1min.</li> <li>▶ Never touch any moving parts (valves and actuators) during operation.</li> </ul>
 <b>Forcing</b>	<p><b>Electric shock or There is a danger of injury.</b></p> <ul style="list-style-type: none"> <li>▶ Be sure to perform safety inspections of the machine tool and power tool beforehand.</li> <li>▶ Wear appropriate protective equipment according to the type of work being performed.</li> </ul>

 <b>Caution</b>	
 <b>Prohibition</b>	<p><b>You may be electrocuted or injured.</b></p> <ul style="list-style-type: none"> <li>▶ Do not perform electric operation with the actuator cover open.</li> <li>▶ Do not perform manual operation while the power is on.</li> <li>▶ Do not operate the motor with the hex key for manual operation attached to the shaft for manual operation.</li> </ul> <p><b>Doing so may damage the actuator.</b></p> <ul style="list-style-type: none"> <li>▶ Do not turn the manual override further than necessary from the fully left-open and fully right-open positions.</li> </ul>
 <b>Forcing</b>	<p><b>There is a risk of electric shock or injury.</b></p> <ul style="list-style-type: none"> <li>▶ Keep hands free of moisture and oil during operation.</li> </ul> <p><b>Doing so may cause the actuator to fail or malfunction.</b></p> <ul style="list-style-type: none"> <li>▶ Confirm that Auto/Manual selector switch is completely switched to the manual operation before operating the manual operation.</li> <li>▶ If you notice an unusual odor, heat, or smoke, immediately turn off the power supply. If any abnormality is found, be sure to consult your dealer or us for inspection.</li> <li>▶ This product uses a switching power supply circuit. If there is a concern about the effects of noise, be sure to check the peripheral devices for malfunctions beforehand.</li> </ul>



## Manual Operation

Necessary items	▶ Hex wrench (Hex 5mm)	▶ Flathead screwdriver
-----------------	------------------------	------------------------

### [Point] : Function of Auto/Manual selector switch

- Switching to the manual (M) mode shuts off the power to the internal motor and stops the actuator operation. This allows the actuator to be stopped by manual operation or in an emergency without interrupting the power supply to the actuator.
- A/M selector switch is designed to switch by pushing it in and turning it 90° to prevent safety and malfunction.

### [Procedure]

- 1) Hold A/M selector and push it in, and turn it clockwise to set the "△" marking from "AUTO (A)" to "MAN (M)." (See Fig. 7-1. When you release your finger, A/M selector is raised.)
- 2) Insert a flathead screwdriver into the manual operation bush on the top of the cover, and turn it counterclockwise to remove the manual operation bush. (See Fig. 7-2.)
- 3) Insert the hex wrench into the shaft for manual operation.

**!** The hexagonal wrench is "standard type" described in JIS B 4648:2008 (Long pattern :85mm/ short pattern :33mm) should be used.

- 4) Turn the hex wrench while observing the indicator. (Refer to Fig. 7-3. Operating revolution: 8 to 9 revolutions/90°)
  - ▶ Clockwise : Valve right open direction
  - ▶ Anti clockwise

**!** A mechanical stopper is built into the left open side and the right open side. Operate it using the following ranges as a guide. (BV23 type:-10 to 100°)

- 5) When manual operation is complete, remove the hex key from the shaft for manual operation.
- 6) Insert a flathead screwdriver into the manual operation bush removed in step 2) and turn it clockwise to attach it to the top of the cover.
- 7) Hold A/M selector and push it in, and turn it counterclockwise to set the "△" mark from "Manual (M)" to "Auto (A)." (When you release the button, A/M selector will pop up.)

Fig.7-1

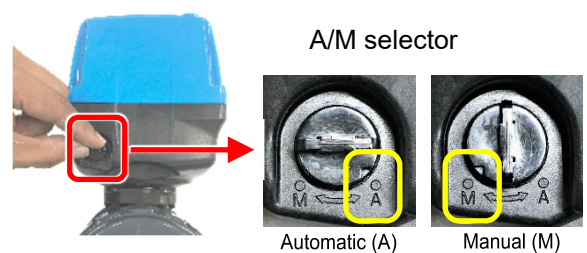

Fig.7-2

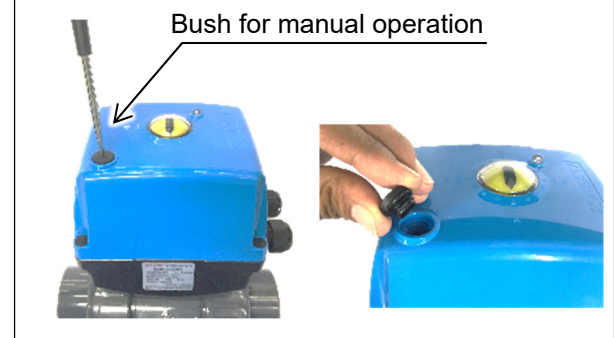

Fig.7-3



## Electric operation

### [Procedure]

- 1) Turn on the power.
- 2) Open the external selector switch to the left or right to check that the valve display direction matches the operating direction.
- 3) Ensure that LED indicator on the top of the cover is lit green or red when the cover is fully open or closed.
- 4) Shut off the power supply to finish the trial run work.

## Water flow test

### [Procedure]

- 1) Flow fluid into the piping.
- 2) Open the external selector switch on the operation panel to the left or right to activate the valve.
- 3) Check that there is no internal (sheet leakage) or external leakage.
- 4) Turn off the power by opening left or right.
- 5) If leakage occurs, refer to "**14. Cause of Malfunction and Remedy**".

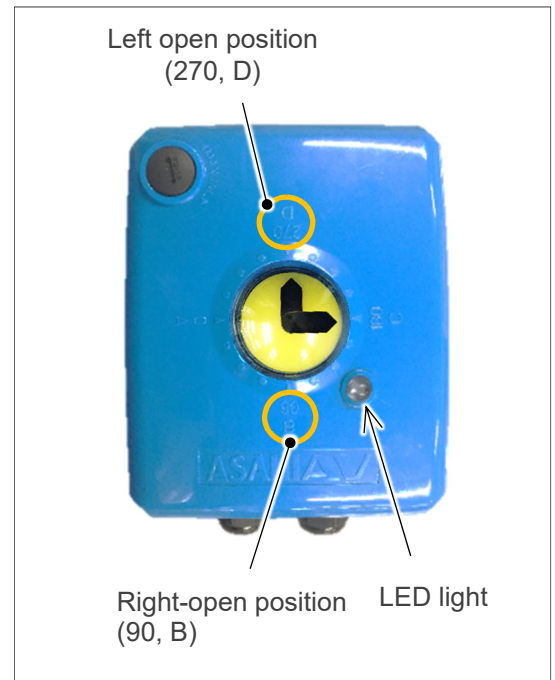



## 8. Improvement of internal leakage (seat leakage)

If internal leakage (seat leakage) occurs when the valve is fully closed to the left or fully closed to the right, seat leakage may be improved by retightening the carrier.

If seat leakage does not improve even after retightening the carrier, replace the valve according to "9. Disassembly/Assembly Method for Replacement of Parts".

### Warning



#### Forcing

**Serious injury can result.**

- ▶ A little fluid remains in the valve. Wear protective gloves and eye protection.

### Caution



#### Prohibition

**The valve can be damaged, damaged, or leak.**

- ▶ Do not overtighten the carrier.
- ▶ Do not overtighten the union nut.
- ▶ Do not use a pipe wrench to tighten the union nut.

Necessary items	▶ Belt Wrench	▶ Handle for manual valve (option)	▶ Protective gloves	
	▶ Protective goggles	▶ Baseplate removal tool (Option, see photo on right)		

## [Procedure]

- 1) Zero the pressure in the piping to completely drain the fluid.
- 2) Follow steps 2) to 6) in <Removal> in "**12. How to Remove/Install Actuator**" to remove the actuator section.
- 3) For products with a shaft adapter on the stem of the valve, also remove the shaft adapter.
- 4) Attach the manual handle to the stem and turn the handle to open the valve to the right.
- 5) Loosen the three union nuts with a belt wrench.
- 6) Remove the body from the piping.
- 7) Remove the handle for the manual valve after removing the fluid remaining in the valve.
- 8) Remove the carrier and the three O-rings (A) at the bottom of the body.
- 9) Mate the convex part of the upper part of the handle for manual valve with the concave part of the carrier.
- 10) Turn the hand wheel for the manual valve and adjust the surface pressure by turning the carrier with reference to **Fig. 8-1**.
- 11) Attach the handle for the manual valve to the stem, and check that manual operation can be performed smoothly.
- 12) After opening the valve to the right with the handle for manual valve, remove the handle for manual valve.
- 13) Attach the O-ring (A) to three points on the carrier and the bottom of the body.
- 14) Return the body part to the piping so that there is no misalignment.
- 15) Screw the three union nuts onto the body until they are hand tight.
- 16) Screw the union nut 1/4 to 1/2 turn to prevent it from being damaged by the belt wrench.
- 17) For products with a shaft adapter on the stem of the valve, attach the shaft adapter to the stem of the valve.
- 18) Attach the actuator part to the valve according to steps 1) to 3) in <Installation> in "**12. How to Remove/Install Actuator**".
- 19) Check that fluid flows into the piping, operates smoothly by turning on the power and operating the valve several times by electric operation, and that there is no external leakage.
- 20) Open the valve to the left or right by motor to check for **seat leakage**.

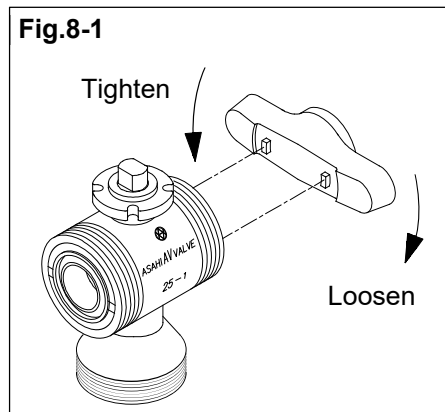
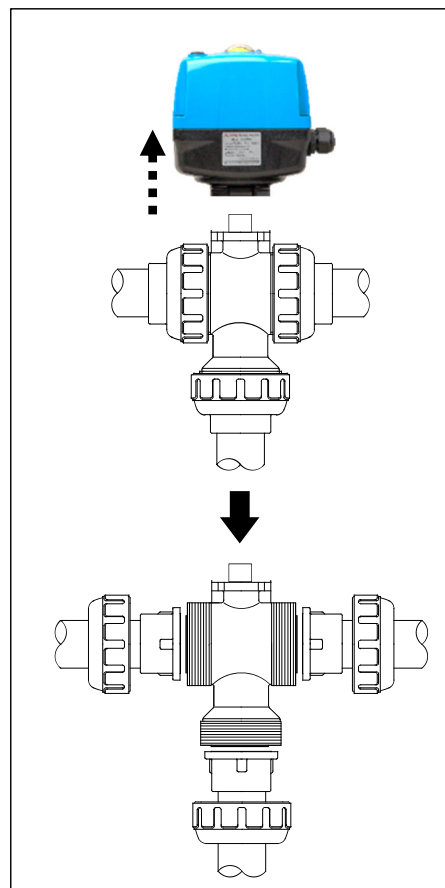

## 9. How to disassemble/assemble parts for replacement

If internal leakage (seat leakage) or external leakage occurs when the valve is fully closed to the left or fully closed to the right, the leakage may be improved by replacing parts.

If the leak does not improve after replacing the parts, remove and replace the valve according to this item.

### Warning



**Forcing**

**Serious injury can result.**

- ▶ A little fluid remains in the valve. Wear protective gloves and eye protection.

### Caution



**Prohibition**

**The valve can be damaged, or leak.**

- ▶ Do not overtighten the carrier.
- ▶ Do not overtighten the union nut.
- ▶ Do not use a pipe wrench to tighten the union nut.

Necessary items	▶ Belt Wrench	▶ Handle for manual valve (Option)	
	▶ Protective gloves.	▶ Protective goggles	
	▶ Base plate removal jig (option; see photo on the right)		

**[Disassembly procedure]**

- 1) Zero the pressure in the piping to completely drain the fluid.
- 2) Follow steps 2) to 6) in <Removal> in "12. How to Remove/Install Actuator" to remove the actuator section.
- 3) For products with a shaft adapter on the stem of the valve, also remove the shaft adapter.
- 4) Loosen the right and left union nuts with a belt wrench.
- 5) Remove the body from the piping.
- 6) Attach the handle for the manual valve to the stem. After removing the fluid remaining in the valve with the valve in the half-opened state, fully close the valve and remove the handle for the manual valve.
- 7) Remove the O-rings (A) attached to both ends of the body part.
- 8) Mate the convex part of the upper part of the handle for the manual valve with the concave part of the carrier.
- 9) Rotate the hand valve handle to remove the carrier. (See Fig. 9-1.)
- 10) Remove the seat, O-ring (B) and O-ring (C) attached to the carrier, taking care not to damage them.
- 11) Push out the ball by hand.
- 12) Push the stem from the top flange side to the body side.
- 13) Remove the seat and O-ring (C) from the body without damaging them.
- 14) Remove the O-ring (D) and O-ring (E) from the stem, taking care not to damage them.

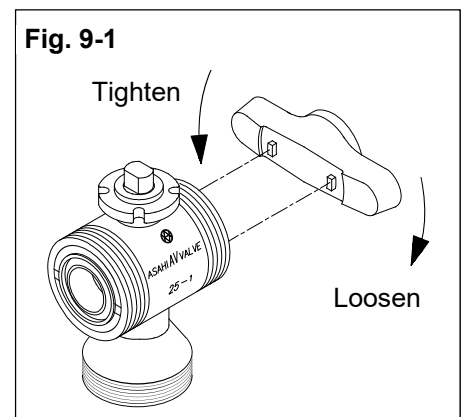
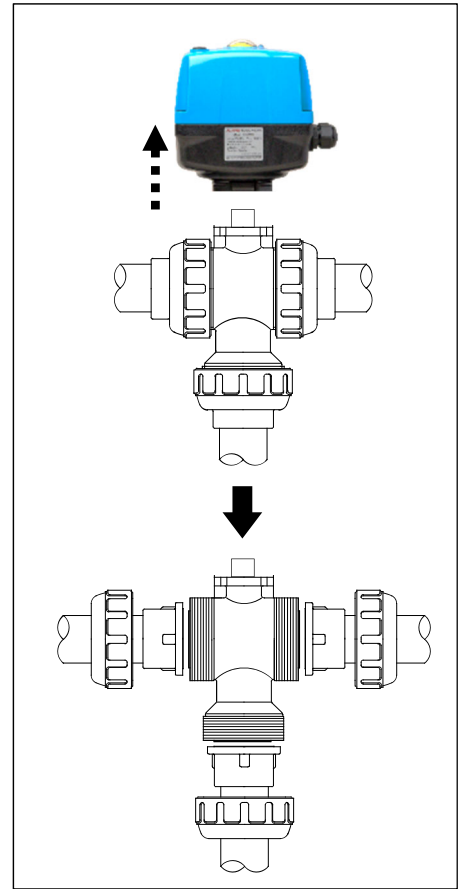

## [Assembly Procedure]

- 1) Attach the thick O-ring (E) and the thin O-ring (D) to the stem in this order.
- 2) Attach O-ring (B) and O-ring (C) to the carrier.
- 3) Check the front and back sides of the sheet and attach it to the carrier so that the side that mates with the ball is on the recessed side. (See Fig. 9-2.)
- 4) Insert the stem from the inside of the body toward the top flange.
- 5) Insert the ball into the body to mate with the stem.
- 6) Screw the carrier onto the body by hand, taking care not to disengage the seat.
- 7) Mate the convex part of the upper part of the handle for the manual valve with the concave part of the carrier.
- 8) Rotate the hand valve handle to screw the carrier further. (See Fig. 9-3.)
- 9) Attach the O-ring (A) to three points on the carrier and the bottom of the body.
- 10) Return the body part to the piping so that there is no misalignment.
- 11) Screw the three union nuts onto the body until they are hand tight.
- 12) Screw the union nut 1/4 to 1/2 turn to prevent it from being damaged by the belt wrench.
- 13) For products with a shaft adapter on the stem of the valve, attach the shaft adapter to the stem of the valve.
- 14) Attach the actuator part to the valve according to steps 1) to 3) in <Installation> in "12. How to Remove/Install Actuator".
- 15) Check that fluid flows into the piping, operates smoothly by turning on the power and operating the valve several times by electric operation, and that there is no external leakage.
- 16) Open the valve to the left or right by motor to check for seat leakage.

**Fig. 9-2**

Dent side = Contact with the ball

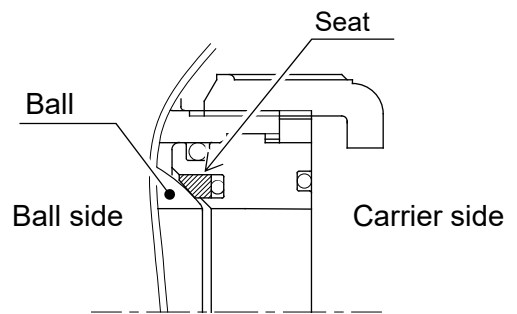

**Fig.9-3**

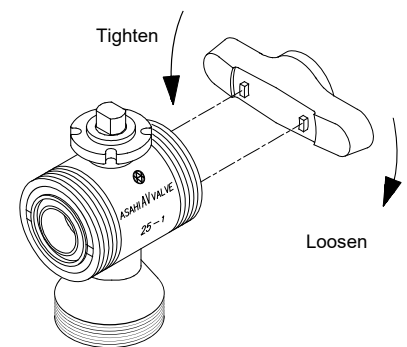





## 10. How to adjust the limit switch

### Caution

#### Forcing

**There is a danger of injury.**

- ▶ To prevent the actuator from moving unintentionally, make adjustments with the power supply turned off.

#### Necessary items

- ▶ Hex wrench (Hex 5mm)
- ▶ Spanner wrench (Width 12mm)
- ▶ Phillips screwdriver

#### [Procedure]

- 1) Push in A/M selector and turn it clockwise to set the "△" marking from "AUTO (A)" to "MAN (M)." (A/M selector raised when you release your hand.)
- 2) Remove the four bolt caps on the cover.
- 3) Loosen the four screws securing the cover with a Phillips screwdriver and remove the cover.
- 4) Insert a hex wrench into the shaft for manual operation.
- 5) Turn the Allen key to adjust the valve opening to the left or right opening position. (See 7. Test Run Methods)
- 6) Insert the wrench into the two-sided part of the cam.
- 7) Rotate the cam and confirm that the limit switch "clicks and clicks" and two-step operation has been performed.
- 8) Turn the Allen key and check that the limit switch operates at the adjusted opening. If the adjustment is insufficient, repeat steps 4) to 7).



A mechanical stopper is built into the left open side and the right open side. Operate it using the following ranges as a guide.  
(BV23 type:-10 to 100°)

- 9) Orient the removed cover according to the "Alignment of the shaft for manual operation" as a guide and install it.
- 10) Tighten the four screws that secure the cover with a Phillips screwdriver to attach the bolt cap.
- 11) Push in A/M selector and turn it counterclockwise to set the "△" stamp from "Manual (M)" to "Auto (A)." (A/M selector raised when you release your hand.)
- 12) Perform an electric operation to check that the indicator pointer is in the left-open or right-open adjustment position.

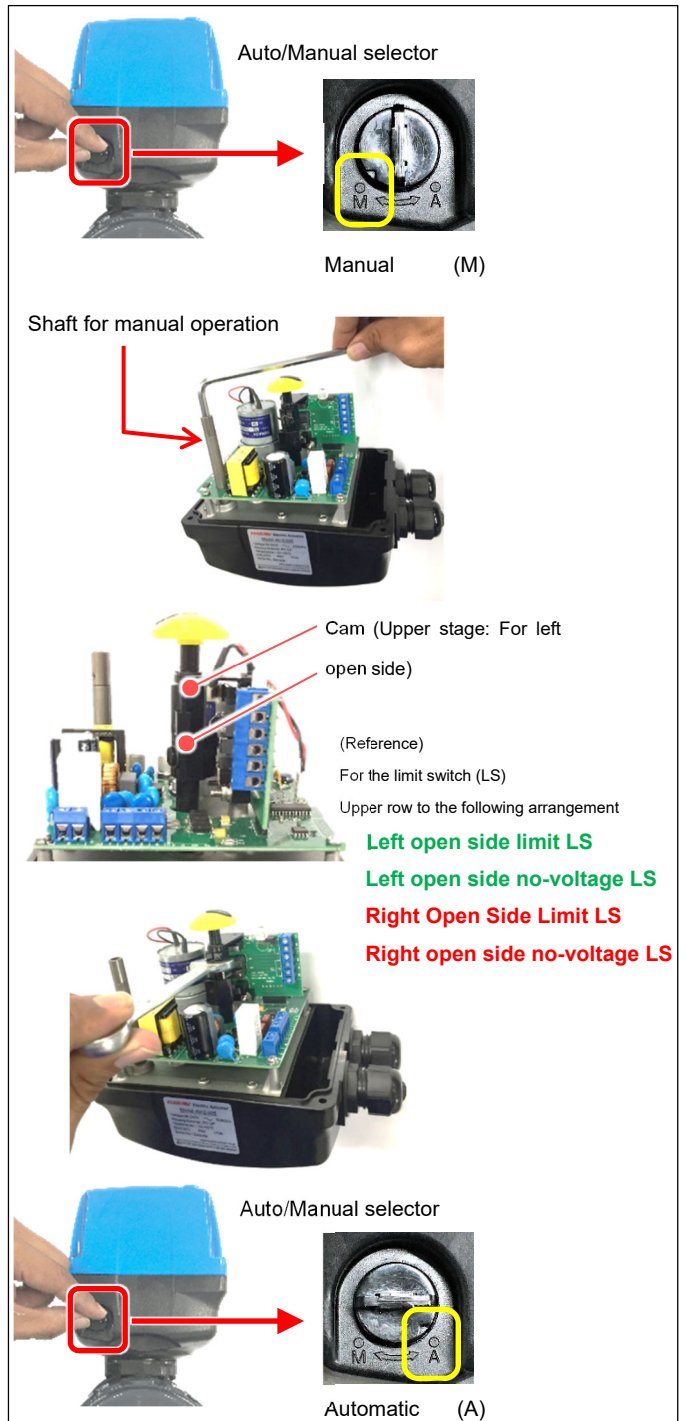

### 11. How to change LED open/close indication

For products with switchable open/close indication LED color, "\*" is listed at the end of the serial number. (Refer to Fig. 11-1.) LED color can be selected by operating the switch on the board. (See Fig. 11-2.)

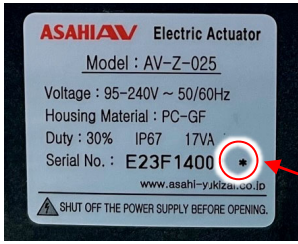

Fig. 11-1: Actuator label

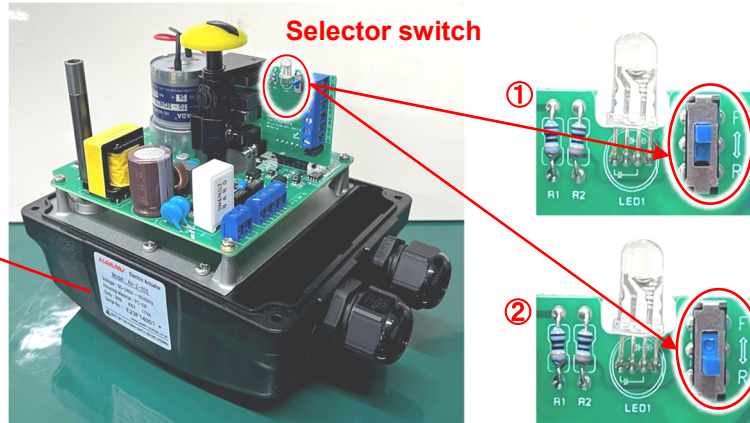

Fig. 11-2: LED color selector

The switchover and LED light colors are shown below. (See Table 11-1.)

Table 11-1: Open/close indication LED light color and switchover

Position of the selector switch	Open/close display	Remarks
<p>①</p>	<p>Right open</p> <p>Left open</p>	<p>Selector switch This position when shipped</p>
<p>②</p>	<p>Right open</p> <p>Left open</p>	

**12. How to remove/install the actuator**

**⚠ Caution**

**⊘ Prohibition**

**Doing so may damage the base plate.**

- ▶ When removing the base plate from the valve, do not apply excessive force to the base plate removal jig to forcibly spread the claw part.
- ▶ Do not replace or remove the base plate excessively.
- ▶ Do not apply excessive load to the piping or valves when installing or removing the base plate.

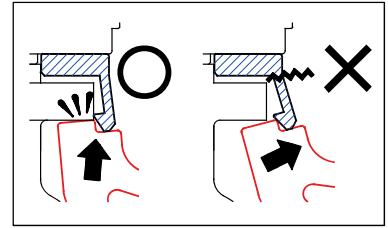

**! Forcing**

**Doing so may damage the base plate.**

- ▶ Be sure to use the base plate removal jig when removing the actuator.

**There is a danger of injury.**

- ▶ There is a metal fitting between the valve and the actuator. When removing the base plate from the valve, be careful not to pop out or drop the fitting.

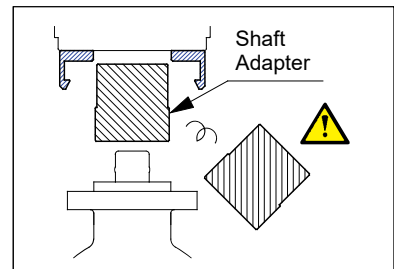

Necessary items

▶ Base plate removal jig (option; see photo on the right)



## <Removal>

[Procedure]

- 1) Sets the pressure in the piping to zero.
- 2) Turn off the power by opening left or right.
- 3) Align the end of the base plate removal jig with the center of one claw of the base plate. (See **Fig. 12-1.**)
- 4) With the side face of the valve as a fulcrum, move the removal jig so that the base plate claw portion is pushed up from below, and remove the hook from the valve body. (See **Fig. 12-2.**)
- 5) Follow Steps 3) to 4) on the other claw to remove the hook from the valve body.
- 6) When both claws are disengaged, lift the actuator vertically and disconnect it from the valve. (See **Fig. 12-3.**)

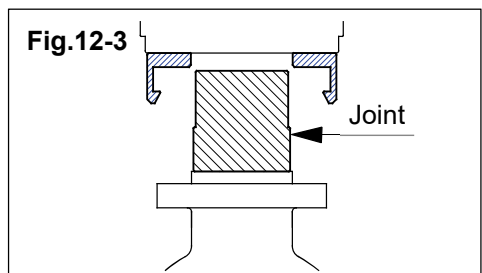
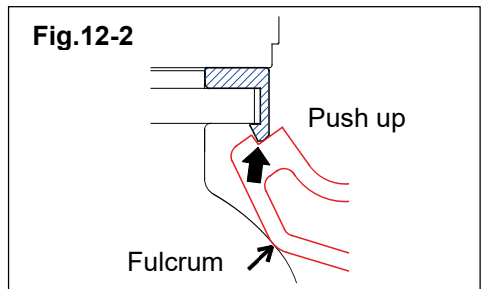
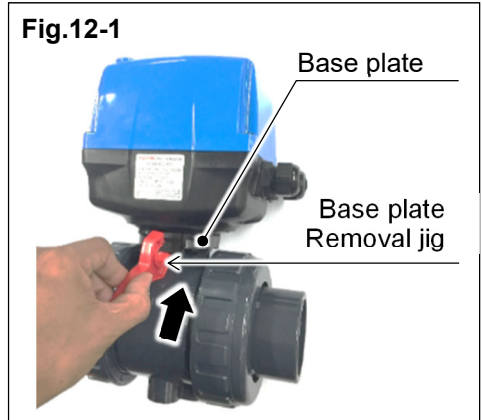

## <Installation>

[Procedure]

- 1) Check that the actuator travel indication is aligned with the valve stem and fitting.
- 2) Check the mating position of the top flange and base plate of the valve.
- 3) Push in the base plate while checking visually until the claw part of the base plate is securely hooked on the top flange.

**13. Inspection item**

 **Caution**



**Forcing**

**Fluid may leak from the valve or the actuator may fail.**

- ▶ Maintenance should be performed every 3 to 6 months as a guide in order to keep the watch in normal condition and use it for a long time. Pay particular attention to temperature changes and aging during long-term storage or shutdown or use.

**You may be electrocuted or injured.**

- ▶ Turn off the power before removing the actuator cover.
- ▶ When removing the valve from the piping when replacing the valve or parts, completely remove the fluid from the piping before starting work.
- ▶ If any trouble is found, take the appropriate action referring to "**14. Cause of trouble and remedy**".

**Daily inspection**

As inspection items Inspection method	Guideline of judgment	Check point	Treatment method
External leakage (visual inspection)	For leakage No	[Flanged end] Pipe flange connection	① Retighten the pipe bolts to the specified torque. ② Remove the valve from the pipe and retighten the pipe bolts. (Ref: 5. Piping method [Flanged end])
		[Socket end] Adhesive construction section	Remove the valve from the piping and retry the bonding process. (Ref: 5. Piping method [Socket end])
		[Threaded end] Threaded connection	Remove the valve from the piping and screw the valve in again. (Ref: 5. Piping method [Threaded end])
		Top flange of the valve	Remove the valve from the piping and replace the valve or defective part. (Ref: 9. How to disassemble/assemble parts for replacement)
		Union nut portion of the valve	① Retighten the union nut ② Remove the valve from the piping, check the O-ring and sealing surface, and replace the defective part. (Ref: 5. Piping method)
		Surface of the entire valve	Remove the valve from the pipe and replace the valve. (Ref: 9. How to disassemble/assemble parts for replacement)
Internal leakage (visual and measurement)	For leakage No	Leakage to secondary side when valve is left closed or right closed	Remove the valve from the piping and replace the valve or defective part. (Ref: 9. How to disassemble/assemble parts for replacement)
		Measured values of flowmeters, pressure gauges, etc.	Remove the valve from the piping and replace the valve or defective part. (Ref: 9. How to disassemble/assemble parts for replacement)
Operating position Displacement (visual inspection)	In a shift No	Actuator opening display	Remove the actuator cover and adjust the limit switch operating position. (Ref: 10. How to adjust limit switch)

## Daily inspection (continued)

As inspection items Inspection method	Guideline of judgment	Check point	Treatment method
Abnormal noise (hearing)	Abnormal noise No	Valves and actuators	Remove the valve from the pipe and replace the valve or actuator. <a href="#">(Ref: 9. How to disassemble/assemble parts for replacement)</a>
		Piping around the valve	Reconfirm the conditions of use <a href="#">(Ref: 2. Safety Instructions)</a>
Odor <b>*1)</b> (sniffing)	With a strange smell No	Valves and actuators	Remove the valve from the pipe and replace the valve or actuator. <a href="#">(Ref: 9. How to disassemble/assemble parts for replacement)</a>

**\*1) Failure to do so may result in burnout or fire.**



## Periodic inspection

### ●Guideline for the inspection cycle: 3 months

As inspection items Inspection method	Guideline of judgment	Check point	Remedy for malfunctions
Left open ~ Right open Operating time (Measurement)	Error within $\pm 1$ second	Actuator opening display	Check the power supply voltage ( $\pm 10\%$ ). (Ref: <a href="#">Actuator nameplate</a> )
			Remove the valve from the pipe and replace the valve or actuator. (Ref: <a href="#">9. How to disassemble/assemble parts for replacement</a> )
Vibration (palpation)	To differences from other parts No	Valves and actuators	Recheck the operating conditions and remove the source of vibration. (Ref: <a href="#">2. Safety Instructions</a> )
			Remove the valve from the pipe and replace the valve or actuator. (Ref: <a href="#">9. How to disassemble/assemble parts for replacement</a> )
		Piping around the valve	Recheck the operating conditions and remove the source of vibration. (Ref: <a href="#">2. Safety instructions</a> )

**●Guideline of the inspection cycle: 6 months**

As inspection items Inspection method	Guideline of judgment	Check point	Remedy for malfunctions
On the manual handle Operability (touch)	Smoothly Turning	Manual operation unit	Remove the valve from the pipe and replace the valve or actuator. (Ref: 9. How to disassemble/assemble parts for replacement)
Of bolts Looseness (visual and palpation)	Loose No	For mounting base + actuator	Retighten the mounting bolts with the following torque. Nominal diameter 15~50mm:8 N-m
		For fixing the actuator cover	Retighten the screws with the following torque Nominal diameter 15~50mm:1 N-m
		Terminal block	Retighten the screws with the following torques Nominal diameter 15~50mm :0.15~0.18 N-m
		[Flanged end] For flange piping	Retighten the pipe bolts to the specified torque. (Ref: 5. Piping method [Flange end])
Water intrusion *1) (visual inspection)	Of the intrusion No	Inside the actuator	Replace the actuator (Ref: 9. How to disassemble/assemble parts for replacement)
Intrusion of foreign matter *1) (visual inspection)	Of the intrusion No	Inside the actuator	Replace the actuator (Ref: 9. How to disassemble/assemble parts for replacement)
Insulation resistance test *1) (Measurement)	50 MΩ or more Having	Inside the actuator	Replace the actuator (Ref: 9. How to disassemble/assemble parts for replacement)
Corrosion or rust *1) (visual inspection)	Corrosion or Of rust No	Appearance of the product and in the actuator	Remove the valve from the pipe and replace the valve or actuator. (Ref: 9. How to disassemble/assemble parts for replacement)
Product damage	No scratches, cracks, or deformation	Appearance of the product	Remove the valve from the pipe and replace the valve or actuator. (Ref: 9. How to disassemble/assemble parts for replacement)

**\*1) Failure to do so may result in burnout or fire.**



## 14. Cause of malfunction and remedy

### Caution



#### Forcing

**You may be electrocuted or injured.**

- ▶ If any malfunction is found, immediately stop using the product and take appropriate action.
- ▶ When removing the valve from the piping when replacing the valve or parts, completely remove the fluid from the piping before starting work.
- ▶ Turn off the power before removing the actuator cover.

Failure phenomenon	Possible cause	Measures and measures
The Allen key does not turn (or cannot turn) during manual operation.	Already left open (or right open)	Rotate the hex wrench in the reverse direction (Ref: 7. Commissioning method)
	The power remains supplied in the opposite direction of the handle operation direction.	Turning the power off and then manually operating
	Foreign matter caught in valve	Remove the valve from the piping, disassemble it, and remove foreign matter. (Ref: 9. How to disassemble/assemble parts for replacement)
	Piping stress is applied to the valve.	Remove the piping stress
	The torque of the valve has increased due to the effects of the fluid (temperature, components, pressure, etc.)	Reconfirm the conditions of use (Ref: 2. Safety Instructions)
Do not open or close with electric operation	The power is off.	Check the voltage and turn on the power.
	Wiring to the terminal block is disconnected.	Stop operation immediately and recheck the connection status. (Ref:4. Wiring Diagram for Product Specifications)
	The cable or the connection inside the actuator is broken.	Replace the cable or the actuator. (Ref: 9. How to disassemble/assemble parts for replacement)
	Left open and right open are simultaneously energized or incorrectly connected to the terminal block	Stop operation immediately and recheck the connection status. (Ref: 4. Wiring Diagram for Product Specifications)
	Power supply voltage is low.	Check the voltage with a tester to obtain the correct voltage.
	Foreign matter caught in valve	Remove the valve from the piping, disassemble it, and remove foreign matter. (Ref: 9. How to disassemble/assemble parts for replacement)

**Cause of malfunction and remedy (continued)**

Failure phenomenon	Possible cause	Measures and measures
Do not open or close with electric operation	Piping stress is applied to the valve.	Remove the piping stress
	The torque of the valve has increased due to the effects of the fluid (temperature, components, pressure, etc.)	Reconfirm the conditions of use (Ref: 2. Safety Instructions)
	The thermal protector is activated.	Stop using the product immediately, and lower the ambient temperature or the opening/closing frequency.
	Water or foreign matter has entered the actuator causing a short circuit.	Stop using the product immediately and replace the actuator. (Ref: 9. How to disassemble/assemble parts for replacement)
	The insulation resistance of the actuator has dropped.	Stop operation immediately, check the insulation resistance, and replace the actuator. (Ref: 9. How to disassemble/assemble parts for replacement)
Fluid leaks even when fully closed left or fully closed right (internal leak)	High fluid pressure	Use below the maximum allowable pressure (Ref: 9. How to disassemble/assemble parts for replacement)
	The carrier is loose.	Remove the valve from the pipe and tighten the carrier to adjust the surface pressure. (Ref: 8. Improvement of Internal Leakage (Seat Leakage))
	Sheet or ball is worn or scratched	Remove the valve from the piping, replace the relevant part, or replace the valve. (Ref: 9. How to disassemble/assemble parts for replacement)
	Missing parts	Remove the valve from the piping and attach the relevant part or replace the valve. (Ref: 9. How to disassemble/assemble parts for replacement)
	Foreign matter caught in valve	Remove the valve from the piping, disassemble it, and remove foreign matter. (Ref: 9. How to disassemble/assemble parts for replacement)
	Piping stress is applied to the valve.	Remove the piping stress

## Cause of malfunction and remedy (continued)

Failure phenomenon	Possible cause	Measures and measures
Fluid leaks from valve (external leak)	Union nut is loose	Retighten the union nut (Ref: 5. Piping method)
	O-ring is scratched, worn, deformed, melted, or altered	Stop using the product immediately, remove the valve from the piping, replace the relevant part, or replace the valve. (Ref: 9. How to disassemble/assemble parts for replacement)
	Scratches or wear are found on the sliding or fixing surfaces of the O-ring.	Stop using the product immediately, remove the valve from the piping, replace the relevant part, or replace the valve. (Ref: 9. How to disassemble/assemble parts for replacement)
	Valve is cracked or broken	Stop using the product immediately, remove the valve from the piping, and replace the valve. (Ref: 9. How to disassemble/assemble parts for replacement)
Actuator is operating but valve is not open or closed	Damaged stem or ball	Stop using the product immediately, remove the valve from the piping, replace the relevant part, or replace the valve. (Ref: 9. How to disassemble/assemble parts for replacement)
The actuator emits a bad smell, heat, or smoke.	Actuator is defective	Stop using the product immediately, remove the valve from the piping, and replace the actuator. (Ref: 9. How to disassemble/assemble parts for replacement)
	Wrong connection to the terminal block	Stop using the product immediately, remove the valve from the piping, and replace the actuator. (Ref: 9. How to disassemble/assemble parts for replacement)
	An overcurrent is flowing to the actuator	Stop using the product immediately, remove the valve from the piping, and replace the actuator. (Ref: 9. How to disassemble/assemble parts for replacement)
	The actuator is affected by lightning.	Stop using the product immediately, remove the valve from the piping, and replace the actuator. (Ref: 9. How to disassemble/assemble parts for replacement)

**Cause of malfunction and remedy (continued)**

Failure phenomenon	Possible cause	Measures and measures
Actuator is corroded	The watch is exposed to chemical liquids.	Stop using the product immediately, remove the valve from the piping, and replace the actuator. <a href="#">(Ref: 9. How to disassemble/assemble parts for replacement)</a>
Valve is corroded or deformed	The watch is exposed to chemical liquids.	Stop using the product immediately, remove the valve from the piping, and replace the valve. <a href="#">(Ref: 9. How to disassemble/assemble parts for replacement)</a>

## 15. How to query for faults or replacements

If the problem is not improved or parts replacement is required after taking measures or corrective actions, check the nameplate on the side of the actuator and the label information attached to the side of the valve, and contact the nearest dealer or our sales office.





**16. Disposal method of residual materials and waste materials**

 <b>Warning</b>	
 <b>Forcing</b>	<p><b>When burnt, toxic gas is generated.</b></p> <p>▶ When disposing of the product or parts, please dispose of them according to the guidelines of each local authority by a professional disposal company.</p>

**Inquiries**

Contact the nearest distributor, our sales office, or our web website for inquiries about this product.

[User's Manual]

3-way Ball Valve Type 23 Electric Type Z  
15~50mm



<https://www.asahi-yukizai.co.jp/en>

Please note that the content of this manual is subject to change without notice.

**January 2024**

[User's Manual] 3-way Ball Valve Type 23 Electric Type Z 15~50mm (1/2"-2")