

Serial No.	H-A010-E-11
------------	-------------

Control Valves

Pneumatic Actuated

Type AV

Nominal Size: 15, 25mm
 Body Material: U-PVC, PVDF

Nominal Size: 50, 80, 100mm
 Body Material: U-PVC

User's Manual

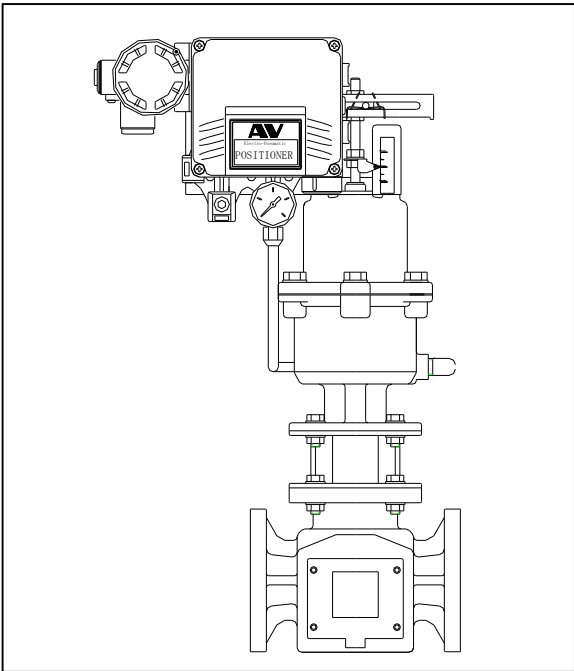



Contents

- (1) Be sure to read the following warranty clauses of our product 1
- (2) General operating instructions 2
- (3) General instructions for transportation, unpacking and storage 3
- (4) Name of parts 4
- (5) Maximum working pressure vs. temperature 7
- (6) Specifications of valve 8
- (7) Specifications of positioner 9
- (8) Specifications of pressure reducing valve with filter 9
- (9) Specifications of tools for disassembling and assembling valve 10
- (10) Installation procedure 11
- (11) Support setting procedure 12
- (12) Air piping procedure 13
- (13) Connecting of E-A positioner procedure 14
- (14) Operation procedure 15
- (15) Method of adjustment positioner 16
- (16) Disassembling method for replacing parts 17
- (17) Countermeasures to avoid leakage 21
- (18) Inspection items 21
- (19) Troubleshooting 22
- (20) Handling of residual and waste materials 22



ASAHI YUKIZAI CORPORATION

This user's guide contains very important information for the proper installation, maintenance and safe use of an ASAHI AV Product. Please store this manual in an easily accessible location.

<Warning & Caution Signs>

 Warning	This symbol reminds the user to take caution due to the potential for serious injury or death.
 Caution	This symbol reminds the user to take caution due to the potential for damage to the valve if used in such a manner.



<Prohibited & Mandatory Action Signs>

	Prohibited: When operating the valve, this symbol indicates an action that should not be taken.
	Mandatory action: When operating the valve, this symbol indicates mandatory actions that must be adhered to.



(1) Be sure to read the following warranty clauses of our product

- Always observe the specifications of and the precautions and instructions on using our product.
- We always strive to improve product quality and reliability, but cannot guarantee perfection. Therefore, should you intend to use this product with any equipment or machinery that may pose the risk of serious or even fatal injury, or property damage, ensure an appropriate safety design or take other measures with sufficient consideration given to possible problems. We shall assume no responsibility for any inconvenience stemming from any action on your part without our written consent in the form of specifications or other documented approval.
- The related technical documents, operation manuals, and other documentation prescribe precautions on selecting, constructing, installing, operating, maintaining, and servicing our products. For details, consult with our nearest distributor or agent.
- Our product warranty extends for one and a half years after the product is shipped from our factory or one year after the product is installed, whichever comes first. Any product abnormality that occurs during the warranty period or which is reported to us will be investigated immediately to identify its cause. Should our product be deemed defective, we shall assume the responsibility to repair or replace it free of charge.
- Any repair or replacement needed after the warranty period ends shall be charged to the customer.
- The warranty does not cover the following cases:
 - (1) Using our product under any condition, not covered by our defined scope of warranty.
 - (2) Failure to observe our defined precautions or instructions regarding the construction, installation, handling, maintenance, or servicing of our product.
 - (3) Any inconvenience caused by any product other than ours.
 - (4) Remodeling or otherwise modifying our product by anyone other than us.
 - (5) Using any part of our product for anything other than the intended use of the product.
 - (6) Any abnormality that occurs due to a natural disaster, accident, or other incident not stemming from something inside our product.

(2) General operating instructions

- 

Warning - Do not disassemble or modify the actuator.
(If disassembled forcible, internal parts may jump out and this is very dangerous.)
- 

- Using a positive-pressure gas with our plastic piping may pose a hazard due to the repellent force particular to compressible fluids even when the gas is under similar pressures used for liquids. Therefore, be sure to take the necessary safety precautions such as covering the piping with protective material. For inquiries, please contact us. For conducting a leak test on newly installed piping, be sure to check for leaks under water pressure. If absolutely necessary to use a gas in testing, please consult your nearest service station beforehand.
- 

Caution - Do not step on or apply excessive weight on valve. (It can be damaged.)

 - Do not use AV valves in a place where they may become submerged in water.
 - Do not remove a dust-proof cap provided to piping port before piping work starts.
 - Do not use the valve in conditions where the fluid may have crystallized.
(The valve will not operate properly.)
- 
 - Products with positioners are adjusted for opening with minimum operating pressure.
Please note that readjustment is required when using at other than the minimum operating pressure.
 - Keep the valve away from excessive heat or fire. (It can be damaged, or destroyed.)
 - Always operate the valve within the pressure vs. temperature range.
(The valve can be damaged or deformed by operating beyond the allowable range.)
 - Allow sufficient space for maintenance and inspection.
 - Select a valve material that is compatible with the media. For chemical resistance information, refer to “CHEMICAL RESISTANCE ON ASAHI AV VALVE”.
(Some chemicals may damage incompatible valve materials.)
 - Keep the valve out of direct sunlight, water and dust. Use cover to shield the valve.
(The valve will not operate properly.)
 - Perform regular maintenance. (Leakage may develop due to temperature changes or periods of prolonged storage, rest, or operation.)
 - Set valve support on the valve.
 - The AV valves must be used within the specifications specifically applicable to the Product.

(3) General instructions for transportation, unpacking and storage



- When suspending and supporting a valve, take care and do not stand under a suspended valve.

Warning



- This valve is not designed to handle impacts of any kind. Avoid throwing or dropping the valve.

Caution

- Avoid scratching the valve with any sharp object.

- Do not over-stack cardboard shipping boxes. Excessively stacked packages may collapse.

- Avoid contact with any coal tar creosote, insecticides, vermicides or paint.

(These chemicals may cause damage to the valve.)



- Store products in their corrugated cardboard boxes. Avoid exposing products to direct sunlight, and store them indoors (at room temperature). Also avoid storing products in areas with excessive temperatures. (Corrugated cardboard packages become weaker as they become wet with water or other liquid. Take care in storage and handling.)

- After unpacking the products, check that they are defect-free and meet the specifications.

(4) Name of parts

Nominal size: 15, 25mm (1/2", 1") / Body material: U-PVC

*Drawing shows E-A positioner of "Air to open" type.

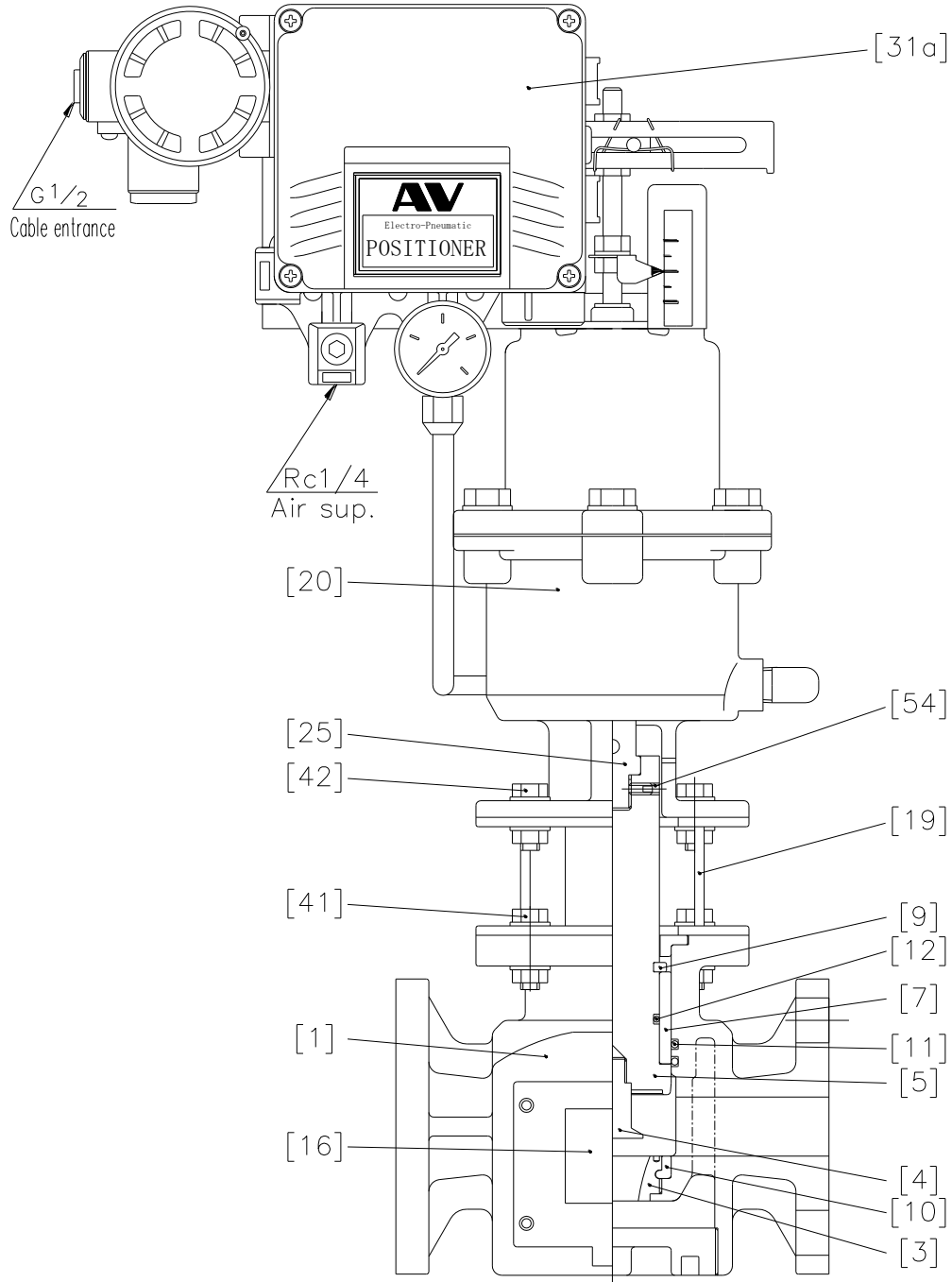

No.	Description	No.	Description	No.	Description
[1]	Body	[10]	Seat	[25]	Stem
[3]	Orifice	[11]	O ring(A)	[31a]	Positioner
[4]	Plug	[12]	O ring(B)	[41]	Bolt·Nut (A)
[5]	Piston (A)	[16]	Name plate	[42]	Bolt·Nut (B)
[7]	Bush	[19]	Stand	[54]	Screw (B)
[9]	Stop ring	[20]	Actuator		

Nominal size: 15, 25mm (1/2", 1") / Body material: PVDF

*Drawing shows E-A positioner of "Air to open" type.

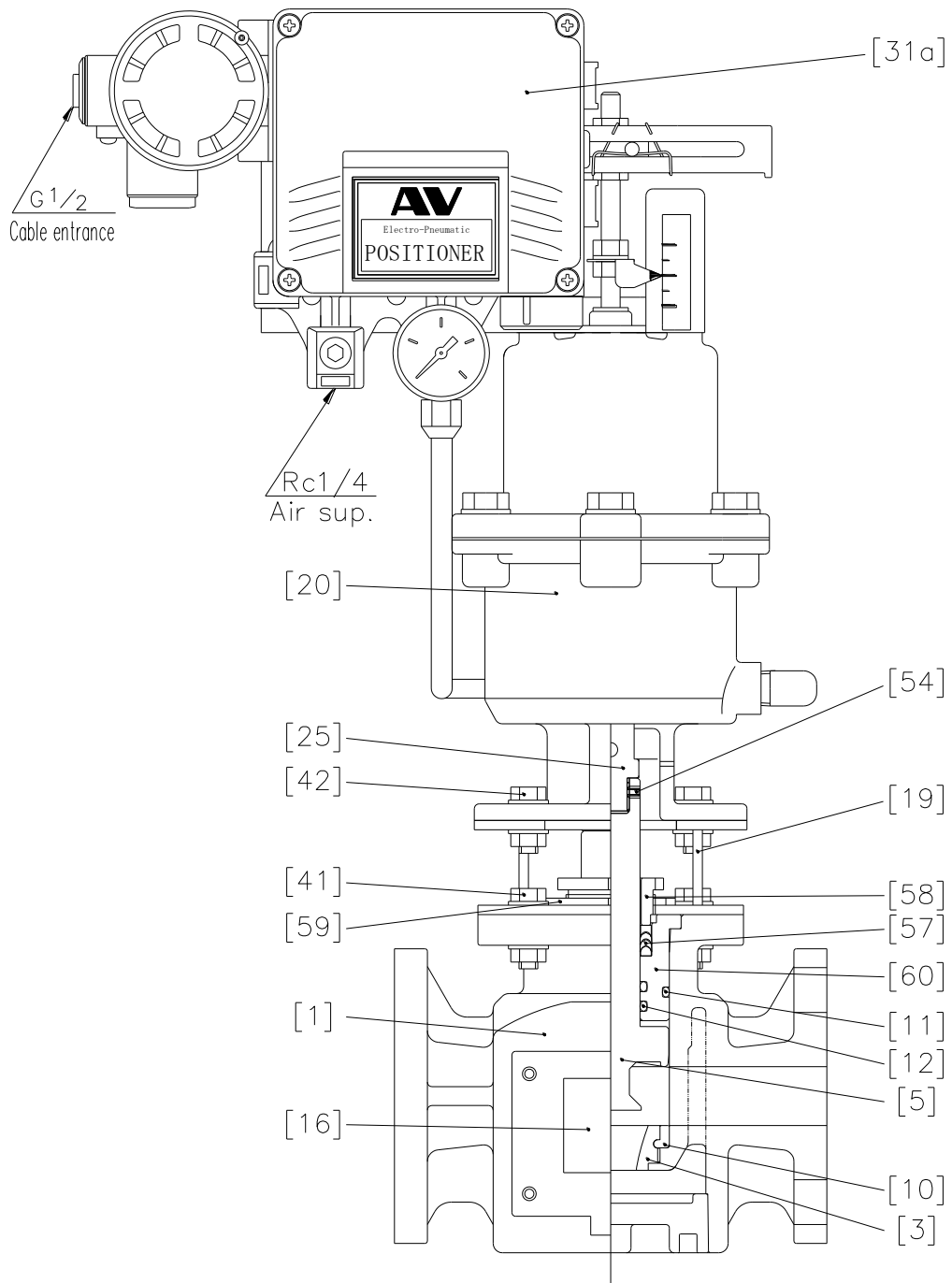

No.	Description	No.	Description	No.	Description
[1]	Body	[16]	Name plate	[42]	Bolt·Nut (B)
[3]	Orifice	[19]	Stand	[54]	Screw (B)
[5]	Piston (A)	[20]	Actuator	[57]	V-Packing
[10]	Seat	[25]	Stem	[58]	Packing holder
[11]	O ring(A)	[31a]	Positioner	[59]	Stopper
[12]	O ring(B)	[41]	Bolt·Nut (A)	[60]	Piston guide

Nominal size: 50, 80, 100mm (2", 3", 4") / Body material: U-PVC

*Drawing shows E-A positioner of "Air to open" type.

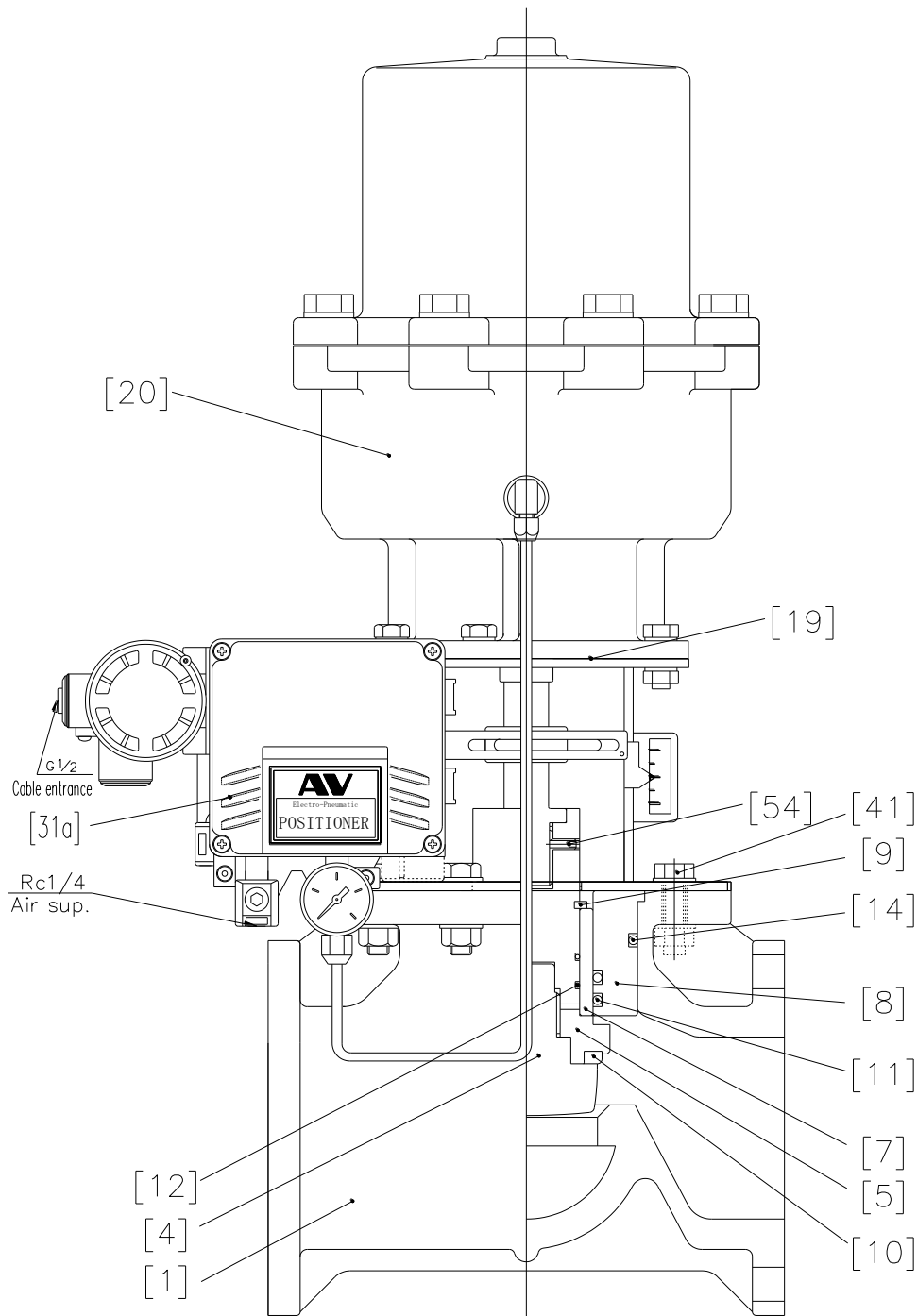

No.	Description	No.	Description	No.	Description
[1]	Body	[9]	Stop ring	[19]	Stand
[4]	Plug	[10]	Seat	[20]	Actuator
[5]	Piston (A)	[11]	O ring (A)	[31a]	Positioner
[7]	Bush	[12]	O ring (B)	[41]	Bolt·Nut (A)
[8]	Bush guide	[14]	O ring (D)	[54]	Screw (B)

(5) Maximum working pressure vs. temperature

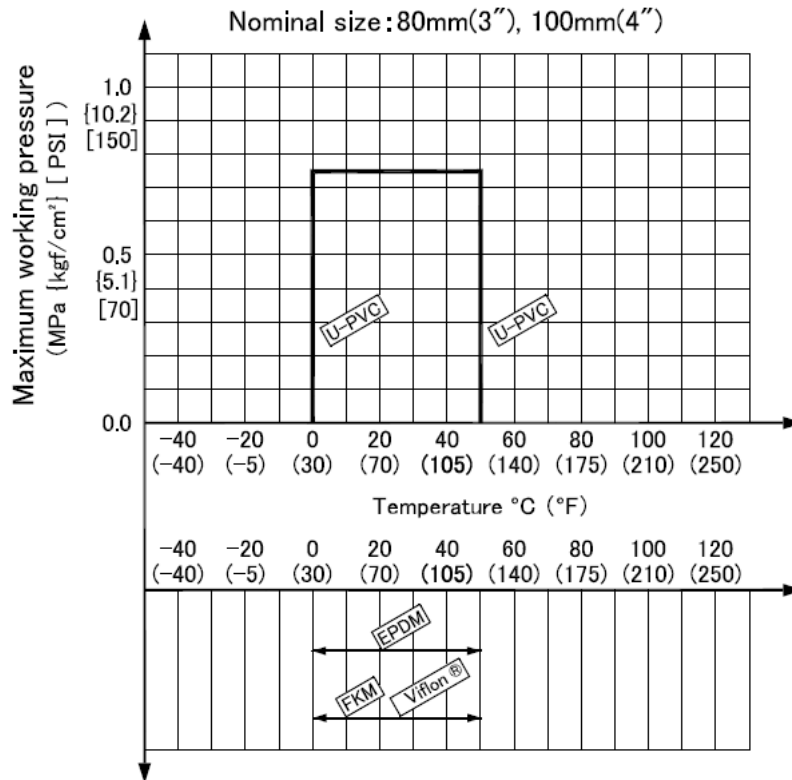
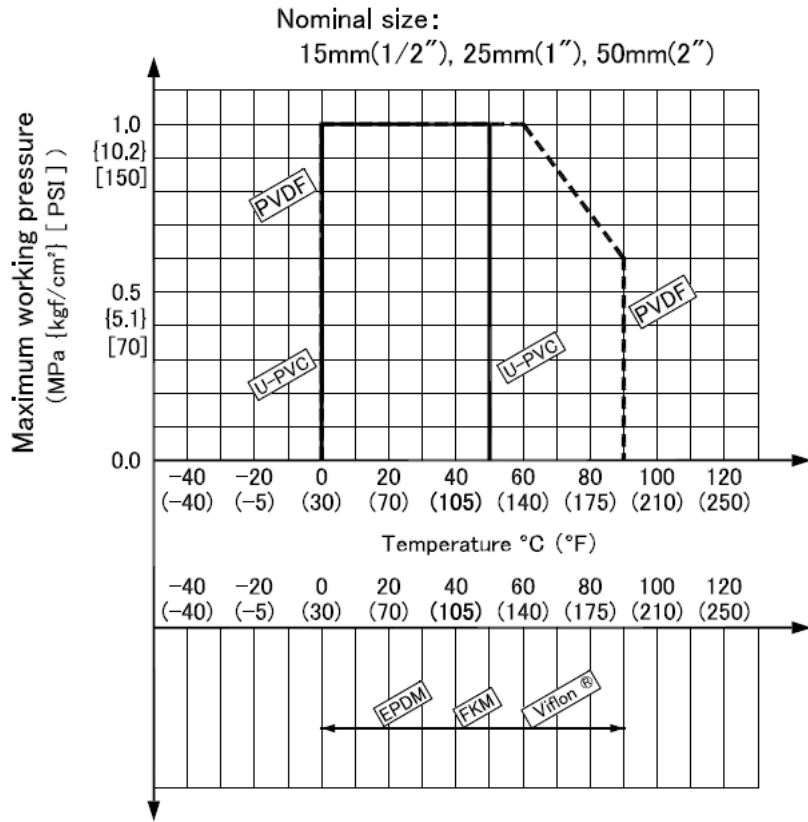

(6) Specifications of valve

Nom. Size		15mm(1/2")	25mm(1")	50mm(2")	80mm(3")	100mm(4")
Type	Double acting Air to open	Single seated control valve Air cylinder type				
Type of Nom. size	Double acting Air to open	- Standard control type - Minute control type	- Standard control type	- Large size control type		
Rated pressure (MPa {kgf/cm ² })	Double acting Air to open	1.0{10.2}	1.0{10.2}	1.0{10.2}	0.75{7.6}	0.75{7.6}
Shut off pressure (MPa {kgf/cm ² })	Double acting	0.7{7.1}	0.7{7.1}	0.7{7.1}	0.65{6.6}	0.65{6.6}
	Air to open	0.7{7.1}	0.7{7.1}	0.7{7.1}	0.7{7.1}	0.7{7.1}
Flow characteristic	Double acting Air to open	Equal % or linear	Equal % or linear	Equal %	Equal %	Equal %
Inherent rangeability	Double acting Air to open	-Standard 50:1 -Minute 20:1	50:1	50:1	50:1	50:1
Operating pressure (MPa {kgf/cm ² })	Double acting Air to open	0.4-0.7 {4.1-7.1}	0.4-0.7 {4.1-7.1}	0.4-0.7 {4.1-7.1}	0.4-0.7 {4.1-7.1}	0.4-0.7 {4.1-7.1}
Air consumption Nl per 1 open and close (MPa {kgf/cm ² })	Double acting	0.6	0.7	2.1	2.1	6.3
	Air to open	1.3	1.5	2.7	5.5	7.9
Air supply bore	Double acting Air to open	Rc 1/4				

(7) Specification of positioner

E-A positioner

Actuation	Nom. Size	Type Sign	Input signal electric current /resistance	Air pipe bore	Electrical connection bore	Protection grade
Double action	15mm (1/2"), 25mm(1")	YT-1000L-SJ111S	DC4-20mA /250Ω	Rc ^{1/4}	G ^{1/2}	Exd II BT5
	50mm(2"), 80mm(3"), 100mm(4")	YT-1000L-SJ131S				
Air to open	15mm (1/2"), 25mm(1")	YT-1000L-SJ111S				
	50mm(2"), 80mm(3"), 100mm(4")	YT-1000L-SJ131S				

A-A positioner

Actuation	Nom. Size	Type Sign	Input signal air pressure (MPa {kgf/cm ² })	Air pipe bore	Protection grade
Double action	15mm (1/2"), 25mm(1")	YT-1200L-S111S	0.02(0.2)-0.10(1.0)	Rc ^{1/4}	IP66
	50mm(2"), 80mm(3"), 100mm(4")	YT-1200L-S131S			
Air to open	15mm (1/2"), 25mm(1")	YT-1200L-S111S			
	50mm(2"), 80mm(3"), 100mm(4")	YT-1200L-S131S			

(8) Specification of pressure reducing valve with filter

Action	Nom. size	Type sign	Pipe bore	Element degree of filtration
Double action Air to open	15mm (1/2") 25mm(1") 50mm(2") 80mm(3") 100mm(4")	AUR2-02-8A-G	Rc ^{1/4}	5μm

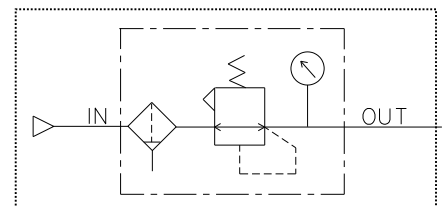

(9) Specification of tools for disassembling and assembling valve

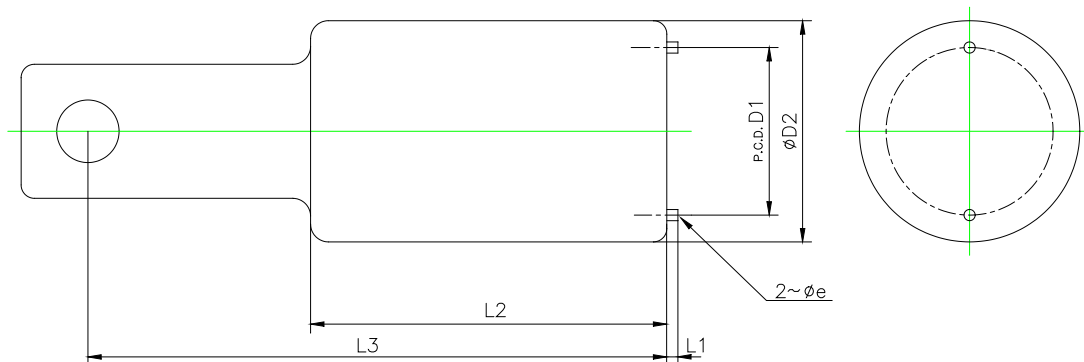

Orifice remover



Dimension table

Nom. size		D ₁	D ₂	L ₁	L ₂	L ₃	e
15mm	1/2"	23.5	35.5	2.5	60	115	2.5
25mm	1"	37.5	49.5	2.5	80	125	2.5

(10) Installation procedure

Warning   - Do not use the valve to fluid containing slurry. (The valve will not operate properly.)



 - The installed valve must never be opened or closed when foreign matter such as sand is present in the pipeline.

- Use flat faced flanges for connection to AV Valves.
- Ensure that the mating flanges are of the same standards.
- Be sure to use sealing gaskets (AV Gasket), bolts, nuts, and washers and tighten them to specified torques. (When a non-AV gasket is used, a different tightening torque specification should be followed.)
- When installing a pipe support by means of a U-band or something similar, take care not to over-tighten. (Excessive force may damage the pipe.)
- When connecting a ASAHI AV Valve to metal piping, take care not to let the pipe stress on the ASAHI AV Valve.

- Necessary items**
- Torque wrench
 - AV gasket

Procedure

- 1) Set the AV gasket between the flanges.
- 2) Insert washers and bolts from the pipe side, insert washers and nuts from the valve side, then temporarily tighten them by hand.

Caution   - The parallelism and axial misalignment of the flange surface should be under the values shown in the following table to prevent damage the valve.
(A failure to observe them can cause destruction due to stress application to the pipe)

Unit: mm (inch)

Nom. Size	Axial Misalignment	Parallelism (a-b)
15, 25mm (1/2", 1")	1.0 (0.04)	0.5 (0.02)
50, 80 (2", 3")	1.0 (0.04)	0.8 (0.03)
100 (4")	1.0 (0.04)	1.0 (0.04)

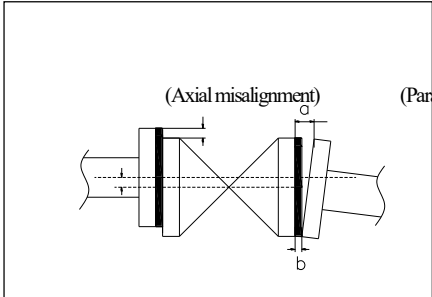

- 3) Using a torque wrench, tighten the bolts and nuts gradually to the specified torque in a diagonal manner (Refer to fig.1.)

Recommended torque value

Unit: N·m {kgf·cm} [lb·inch]

Nom. Size	15 mm (1/2")	25 mm (1")	50 mm (2")	80, 100 mm (3", 4")
PTFE·PVDF coated	17.5 {179} [155]	20.0 {204} [177]	22.5 {230} [230]	30.0 {306} [266]
Rubber	8.0 {82} [71]	20.0 {204} [177]	22.5 {230} [230]	30.0 {306} [266]

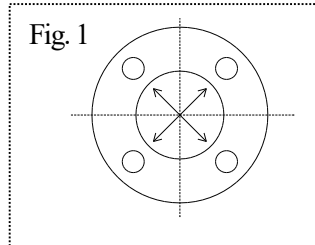

(11) Support setting procedure

- Caution**
- Do not subject the valve to pump vibrations. (The valve may be damaged.)
 - When installing a pipe support by means of a U-band or something similar, take care not to fasten it too much. (Excessive tension may damage it.)
 - Valves must be supported. (The valve may be damaged by the weight of the actuator if it is unsupported.)

Necessary items

- Spanner wrench
- U-type clamp (with bolt)
- Rubber sheet

Level installation

Set the stand under the valve.

Only for nominal size 15, 25mm (1/2", 1"), the Ensats which is equipped to the body enables the valve to fix to the stand. Refer to the chart below.

Dimension of Ensats

Nominal Size	15, 25mm (1/2", 1")
Ensats	M6

Spread the rubber sheet on the pipe and secure with U-type clamp.

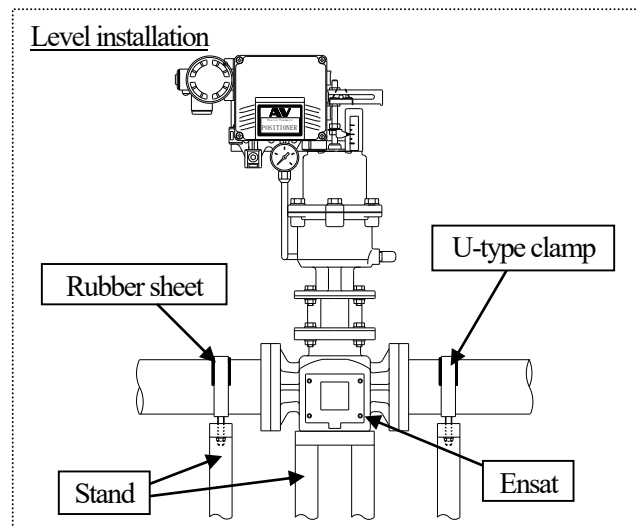

Perpendicular installation

Set the stand under the actuator and the actuator stand.

Only for nominal size 15, 25mm (1/2", 1"), the Ensaf which is equipped to the body enables the valve to fix to the stand. Refer to the chart above.

Spread the rubber sheet on the pipe and secure with U-type clamp.

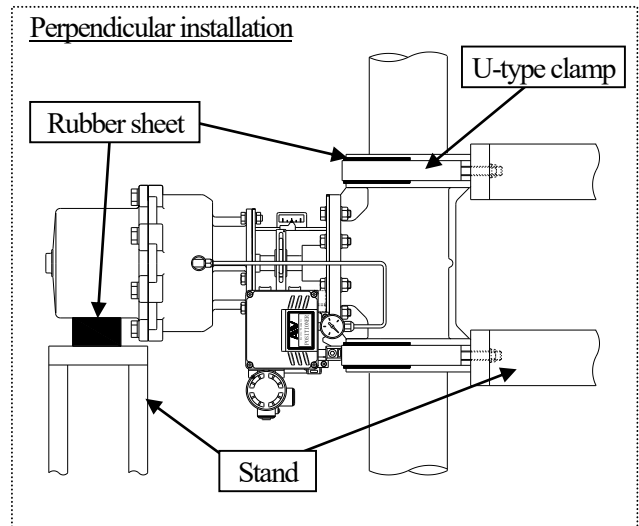

(12) Air piping procedure

<1> For a standard type and an attached speed controller type



Caution



- Do not remove a dust-proof cap provided to piping port before piping work starts.

- Avoid excessive tightening. (The threaded area of a pipe can be damaged.)

- Do not apply a sealant excessively lest it fall off in the pipeline when an actuator is piped.



- Check the connection locations, air pipe sizes, and screw types with the approved drawings and other documents for the product. Then lay the air piping.

- The operating fluid must be clean air filtered through a pertinent air filter.

- If the actuator is used in an environment below 5°C temperature, its operating fluid must be free from the water and moisture contained in it because of possible problems due to the freeze.

- Steel pipes must always be of the plated.

- Before installing an actuator in pipeline, flash the inside of pipeline completely.

- Threaded area of a pipe must be free from the sharp edges and burr.

Necessary items

● Steel pipe or tube for piping

● Spanner wrench

● Joint for steel pipe or tube

● Seal tape (If seal tape isn't used, leakage may be caused)

Procedure

- 1) Wind a seal tape onto the male screw of the joint with a blank about 3mm (about 2 threads) left at the end.
- 2) Tighten the joint to the piping port of positioner or pressure reducing valve with filter by hand.
- 3) Screw the joint one turn with a spanner wrench.
* Avoid excessive tightening.
(The valve can be damaged.)
- 4) Mount a steel pipe or a tube.

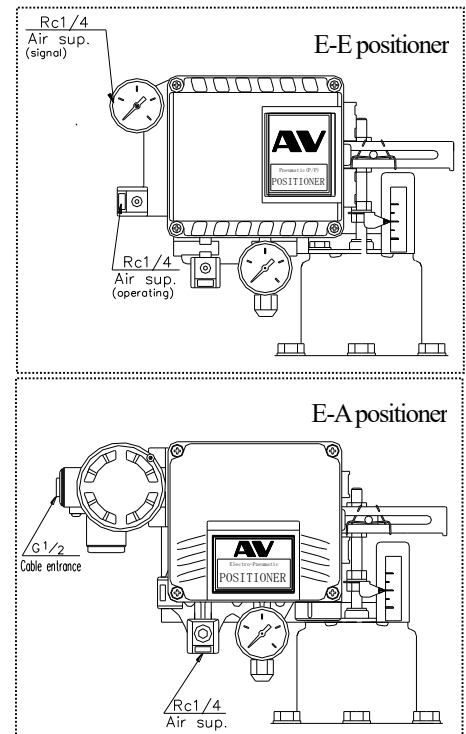

*E-A positioner has no signal air piping port.

(13) Connection of electric-pneumatic positioner procedure

Necessary items

- Screwdriver (+)
- Connector (G1/2)
- Terminal crimping tool
- Allen wrench
- Wire stripper

Procedure

- 1) Loosen the terminal cover attaching a screwdriver (+) to the space of terminal board cover.
- 2) Pull the piping port protective cap off.
- 3) Draw the cable thorough the connector.
- 4) Strip the cable with a wire stripper.
- 5) Loosen screws of the crimp-style terminal, which is in the terminal board with a screwdriver (+) and remove it.
- 6) Install the crimp-style terminal on the lead wire with a terminal-crimping tool.
- 7) Connect to the terminal screws with a screwdriver in accordance with the indication of terminal board. (Refer to fig.2)
※Tighten the screws. (If not, electric leaks or shocks may occur.)

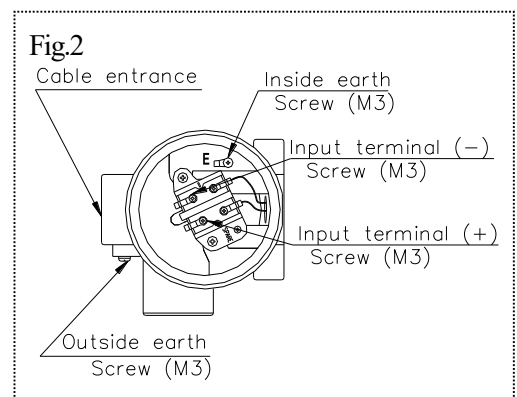
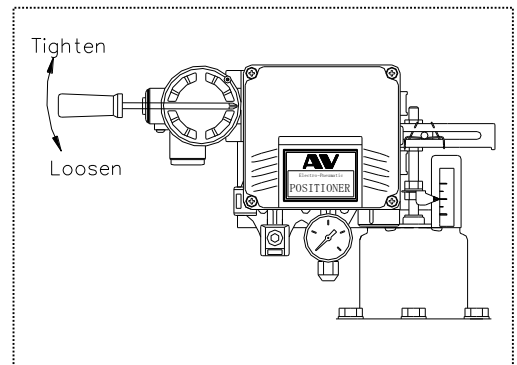

- 8) Tighten the connector to fix the cable.
- 9) Tighten the terminal board cover to the terminal board by hand.
- 10) Tighten the terminal board cover attaching the screwdriver (+) to the space of terminal board cover.
- 11) Tighten screws fixed the terminal board with a hexagon wrench.

(14) Operating procedure



Caution

- As for the E-A positioner, do not leave the terminal board cover. (The valve may be damaged.)



- Keep air supply pressure from the pressure reducing valve with filter at least 0.4MPa {4.1kgf/cm²}
(The valve may not function.)

Procedure

- 1) Supply air to the air supply opening.
- 2) Input the signal electric current, DC4-20mA for the E-A positioner and 0.02MPa {0.2kgf/cm²} [2.9psi] - 0.10MPa {1.0kgf/cm²} [14.5psi] for the A-A positioner.
- 3) Change the input signal and make sure that the travel indicator shows as below.

Input signal for E-A positioner (mA)	4	8	12	16	20
Input signal for A-A positioner (MPa {kgf/cm ² } [psi])	0.02 {0.2} [2.9]	0.04 {0.4} [5.8]	0.06 {0.6} [8.7]	0.08 {0.8} [11.6]	0.10 {1.0} [14.5]
The valve travel indicator (%)	0	25	50	75	100

- 4) Turn off the input signal.
- 5) Stop supplying air.

(15) Method of adjusting positioner

Necessary items

- Screwdriver(+)
- Screwdriver(-)

Procedure

- 1) Loosen the screws fixed the positioner cover with a screwdriver (+) and remove the cover.
- 2) Supply air to the air supply bore.
- 3) Input the signal electric current, DC4mA for the E-A positioner. (Input the signal air, 0.02MPa {0.2kgf/cm²} for the A-A positioner.)
- 4) Fully close the valve turning the zero point adjusting knob “+” and “-”.
- 5) Input the signal electric current, DC20mA for the E-A positioner. (Input the signal air, 0.02MPa {0.2kgf/cm²} for the A-A positioner.)
- 6) Loosen the lock screw fixed the range adjuster with a screwdriver (+).
- 7) Fully open the valve turning the range adjuster.
- 8) Change the input signal and make sure that the signal and the travel indicator accord with each other. (Refer to page 13)
- 9) Tighten the lock screw fixed the range adjuster with a screwdriver (+).
- 10) Fix the positioner cover and tighten the screws with a screwdriver (+).

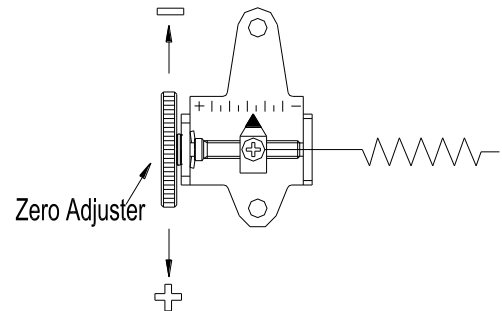

Zero Point adjusting Knob

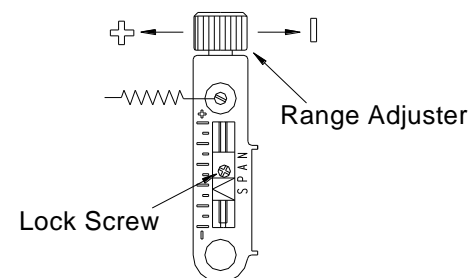

Range adjusting Knob



(16) Disassembling method for replacing parts

-   - Never attempt to disassemble an actuator.
 (If disassembled forcible, internal parts may jump out and this is very dangerous.)
- Warning**
-  - Be sure to conduct a safety check on all hand and power tools to be used before beginning work.
 - Wear protective gloves and safety goggles as fluid remain in the valve even if the pipeline is empty. (You may be injured.)

Nominal size: 15, 25mm (1/2", 1") / Body material: U-PVC, PVDF / Air to open

Necessary items

- Protective gloves
- Safety goggles
- Spanner wrench
- Allen wrench
- Marker pen
- Orifice remover
- Screwdriver (-) (Only required for PVDF made Products)

<Disassembly>

Procedure

- 1) Completely discharge fluid from pipes.
- 2) Close the main valve for air and discharge air from the actuator.
- 3) Remove the air piping from air supply bore of positioner.
- 4) As for the E-A positioner, turn off the electric input signal and remove the wiring.
 As for the A-A positioner, close the main valve for input signal air, and set the input signal pressure at zero then remove the input signal air pipe.
- 5) Loosen and remove the bolt-nut of coupled flange.
- 6) Remove the valve from the pipe.
- 7) Loosen the joint of air piping port on the actuator [20] side and remove it.
- 8) Supply the air, 0.4MPa (4.1kgf/cm²) [58 psi], to the air piping port of actuator [20] and open the valve fully.
- 9) Put a mark between the actuator [20] and body [1] with a marker pen.
- 10) Loosen the coupled bolt-nuts [41] of the body [1] and stand [19] and remove them.
- 11) Lift the actuator [20] with stand [19] up and remove it from the body.
 * Lift the actuator [20] up gently and perpendicularly. (Parts may be scratched.)
- 12) Stop supplying air to the actuator [20] and discharge it to close.
- 13) Loosen the screw (B) [54].
- 14) Turn the piston (A) [5] counterclockwise and remove it without damaging it.
- 15) Loosen the coupled bolt-nuts [42] of the actuator [20] and stand [19] and remove them.

Body material: U-PVC

- 16) Remove the stop ring [9] from the piston (A) [5].
- 17) Pull the bush [7] out of the piston (A) [5].
 * The plug [4] can not be removed because it is screwed in the piston (A) [5] after adhered.
 (If removed by force, the valve may be damaged.)
- 18) Loosen the orifice [3] with a tool for turning the orifice and remove it.

Body material: PVDF

- 16) Pull the piston guide [60] out of the piston (A) [5].
- 17) Loosen the stopper [59] and the packing holder [58] and remove them from the stand [19].
- 18) Loosen the orifice [3] with an orifice remover, turn the orifice and remove it.

<Assembly>

Procedure

- 1) Before starting assembly, silicone grease (fluorine grease is suitable for the chlorine fluid) should be spread on the sliding surfaces and sealing parts, for instance, body [1], piston (A) [5], bush [7] (body material: U-PVC), piston guide [60] (body material: PVDF) and each O-rings.
- 2) Carry out the assembly work in the reverse procedure from item 18).
 - *When tightening the bolt·nut [41], tighten them lightly, and open and close the valve a few times. Make sure that there isn't any problem, then tighten them up completely.

Nominal size: 15, 25mm (1/2", 1") / Body material: U-PVC, PVDF / Double acting

Necessary items

- | | | |
|--|------------------|-------------------|
| ● Protective gloves | ● Safety goggles | ● Spanner wrench |
| ● Allen wrench | ● Marker pen | ● Orifice remover |
| ● Screwdriver (-) (Only required for PVDF made Products) | | |

<Disassembly>

Procedure

- 1) Completely discharge fluid from pipes.
- 2) Close the main valve for air and discharge air from the actuator.
- 3) Remove the air piping.
- 4) As for the E-A positioner, turn off the electric input signal and remove the wiring.
As for the A-A positioner, close the main valve for input signal air, and set the input signal pressure at zero then remove the input signal air pipe.
- 5) Loosen and remove the bolt-nut of coupled flange.
- 6) Remove the valve from the pipe.
- 7) Loosen the joint of air piping port on the actuator [20] side and remove it.
- 8) Put a mark between the actuator [20] and body [1] with a marker pen.
- 9) Loosen the coupled bolt-nuts [41] of the body [1] and stand [19] and remove them.
- 10) Lift the actuator [20] with stand [19] up and remove it from the body [1].
 - * Lift the actuator [20] up gently and perpendicularly. (Parts may be scratched.)
- 11) Loosen the screw (B) [54].
- 12) Turn the piston (A) [5] counterclockwise and remove it without damaging it.
- 13) Loosen the coupled bolt-nuts [42] of the actuator [20] and stand [19] and remove them.

Body material: U-PVC

- 14) Remove the stop ring [9] from the piston (A) [5].
- 15) Pull the bush [7] out of the piston (A) [5].
 - * The plug [4] can not be removed because it is screwed in the piston (A) [5] after adhered (If removed by force, the valve may be damaged.)
- 16) Loosen the orifice [3] with a tool for turning the orifice and remove it.

Body material: PVDF

- 14) Pull the piston guide [60] out of the piston (A) [5].
- 15) Loosen the stopper [59] and the packing holder [58] and remove them from the stand [19].
- 16) Loosen the orifice [3] with an orifice remover, turn the orifice and remove it.

<Assembly>

Procedure

- 1) Before starting assembly, silicone grease (fluorine grease is suitable for the chlorine fluid) should be spread on the sliding surfaces and sealing parts, for instance, body [1], piston (A) [5], bush [7] (body material: U-PVC), piston guide [60] (body material: PVDF) and each O-rings.
- 2) Carry out the assembly work in the reverse procedure from item 16).
 - *When tightening the bolt·nut [41], tighten them lightly, and open and close the valve a few times. Make sure that there isn't any problem, then tighten them up completely.

Nominal size: 50, 80, 100mm (2", 3", 4") / Body material: U-PVC / Air to open

Necessary items

- | | | |
|---------------------|------------------|------------------|
| ● Protective gloves | ● Safety goggles | ● Spanner wrench |
| ● Allen wrench | ● Marker pen | |

<Disassembly>

Procedure

- 1) Completely discharge fluid from pipes.
- 2) Close the main valve for air and discharge air from the actuator.
- 3) Remove the air piping.
- 4) As for the E-A positioner, turn off the electric input signal and remove the wiring.
As for the A-A positioner, close the main valve for input signal air, and set the input signal pressure at zero then remove the input signal air pipe.
- 5) Loosen and remove the bolt-nut of coupled flange.
- 6) Remove the valve from the pipe.
- 7) Loosen the joint of air piping port on the actuator [20] side and remove it.
- 8) Supply the air, 0.4MPa {4.1kgf/cm²} [58psi], to the air piping port of actuator [20] and open the valve fully.
- 9) Put a mark between the actuator [20] and body [1] with a marker pen.
- 10) Loosen the coupled bolt-nuts [41] of the body [1] and stand [19] and remove them.
- 11) Lift the actuator [20] with stand [19] up and remove it from the body [1].
 - * Lift the actuator [20] up gently and perpendicularly. (Parts may be scratched.)
- 12) Stop supplying air to the actuator [20] and discharge it to close.
- 13) Loosen the screw (B) [54].
- 14) Loosen the piston (A) [5] counterclockwise and remove it without damaging it.
- 15) Pull the bush guide [8] out of the bush [7].
- 16) Remove the stop ring [9] from the piston (A) [5].
- 17) Pull the bush [7] out of the piston (A) [5].
 - * The plug [4] can not be removed because it is screwed in the piston (A) [5] after adhered.
(If removed by force, the valve may be damaged.)

<Assembly>

Procedure

- 1) Before starting assembly, silicone grease (fluorine grease is suitable for the chlorine fluid) should be spread on the sliding surface and sealing parts, for instance, body [1], piston (A) [5], bush [7], bush guide [8], each O-rings.
- 2) Carry out the assembly work in the reverse procedure from item 17).
 - *When tightening the bolt·nut [41], tighten them lightly, and open and close the valve a few times. Make sure that there isn't any problem, then tighten them up completely.

Nominal size: 50, 80, 100mm (2", 3", 4") / Body material: U-PVC / Double acting

Necessary items

- Protective gloves
- Safety goggles
- Spanner wrench
- Allen wrench
- Marker pen

<Disassembly>

Procedure





- 1) Completely discharge fluid from pipes.
- 2) Close the main valve for air and discharge air from the actuator.
- 3) Remove the air piping.
- 4) As for the E-A positioner, turn off the electric input signal and remove the wiring.
As for the A-A positioner, close the main valve for input signal air, and set the input signal pressure at zero then remove the input signal air pipe.
- 5) Loosen and remove the bolt-nut of coupled flange.
- 6) Remove the valve [1] from the pipe.
- 7) Loosen the joint of air piping port on the actuator [20] side and remove it.
- 8) Put a mark between the actuator [20] and body [1] with a marker pen.
- 9) Loosen the coupled bolt-nuts [41] of the body [1] and stand [19] and remove them.
- 10) Lift the actuator [20] with stand [19] up and remove it from the body [1].
* Lift the actuator [20] up gently and perpendicularly. (Parts may be scratched.)
- 11) Loosen the screw (B) [54].
- 12) Turn the piston (A) [5] counterclockwise and remove it without damaging it.
- 13) Pull the bush guide [8] out of the bush [7].
- 14) Remove the stop ring [9] from the piston (A) [5].
- 15) Pull the bush [7] out of the piston (A) [5].
* The plug [4] can not be removed because it is screwed in the piston (A) [5] after adhered (If removed by force, the valve may be damaged.)

<Assembly>

Procedure

- 1) Before starting assembly, silicone grease (fluorine grease is suitable for the chlorine fluid) should be spread on the sliding surface and sealing parts, for instance, body [1], piston (A) [5], bush [7], bush guide [8], each O-rings.
- 2) Carry out the assembly work in the reverse procedure from item 15).
*When tightening the bolt·nut [41], tighten them lightly, and open and close the valve a few times. Make sure that there isn't any problem, then tighten them up completely.

(17) Countermeasures to avoid leakage (only for body material PVDF)

-   - Be sure to conduct a regular replacement of damaged parts for permanent measures. (The structure of tightening the 'Packing Holder' is for emergency measures against the leakage from the slide piston.)
-   - Do not tighten the stopper and the packing holder excessively. (Can damage the products)
-  - Perform regular maintenance. (Leakage may develop due to temperature changes or over periods of prolonged storage, rest or in operation.)



Necessary items

- Protective gloves
- Safety goggles
- Screwdriver (-)

Procedure

- 1) Turn the stopper [59] counterclockwise by using a screwdriver.
- 2) Tighten the packing holder [58] clockwise by using a screwdriver properly.
- 3) Fix the packing holder [58] and tighten the stopper [59] clockwise.

(18) Inspection items

-   - Perform regular maintenance. (Leakage may develop due to temperature changes or over periods of prolonged storage, rest or operation.)



- Periodically inspect and maintain the AV valve in accordance with the decided schedule.

Portion to be inspected	Inspection item
Actuator	<ul style="list-style-type: none"> - Existence of rust, corrosion. - Tightening condition of respective threaded portions. (Loose or not) - Existence of abnormality in opening and closing operating sounds. * It is unnecessary to supply oil to this actuator.
Valve	<ul style="list-style-type: none"> - Existence of scratches, cracks, deformation, and discoloring. - Tightening condition of respective threaded portions. (Loose or not) - Existence of leakage when the valve is closed fully.
Positioner	<ul style="list-style-type: none"> - Existence of scratches, cracks, deformation, discoloring and rust. - Tightening condition of respective threaded portions. (Loose or not) - Existence of air leakage from the air piping.

(19) Troubleshooting

Problem	Cause	Treatment
The valve does not operate.	The input signal can not be inputted in to the positioner.	Input the input signal.
	The connection of input signal for the E-A positioner is disconnected.	Check the connection. (Refer to page 13)
	Air is not supplied.	Supply air.
	The air pressure is low.	Check the air pressure.
	Foreign matter is in the valve.	Disassemble the valve to remove foreign matter. (Refer to page 11)
Fluid leaks from the valve even when the valve is closed fully.	The seat is worn.	Replace the seat with a new one.
	The seat, piston or body is scratched.	Replace the scratched seat, piston or body with new ones..
	Foreign matter is in the valve.	Discharge the foreign matter from the valve by opening and closing the valve several times.
	Zero point shifted.	Adjust the positioner.
Fluid leaks from the valve.	The O ring is scratched or worm.	Replace the O ring with a new one.
	The O ring is projected from the groove.	
	The sliding face or the fixed face of the O ring is scratched or worm.	Replace the sliding face or the fixed face with a new one.

(20) Handling of residual and waste materials



 - Make sure to consult a waste treatment dealer for recommendations on the proper disposal of plastic valves. (Poisonous gas is generated when the valve is burned improperly.)

**Control Valves
Pneumatic Actuated Type AV**

[Automatic Valve]

ASAHI YUKIZAI CORPORATION

Distributor

<http://www.asahi-yukizai.co.jp/en/>

Information in this manual is subject to change without notice.

2020.2